

Kwik-Trench[®]

earth saw

**MODEL
KT2400B**

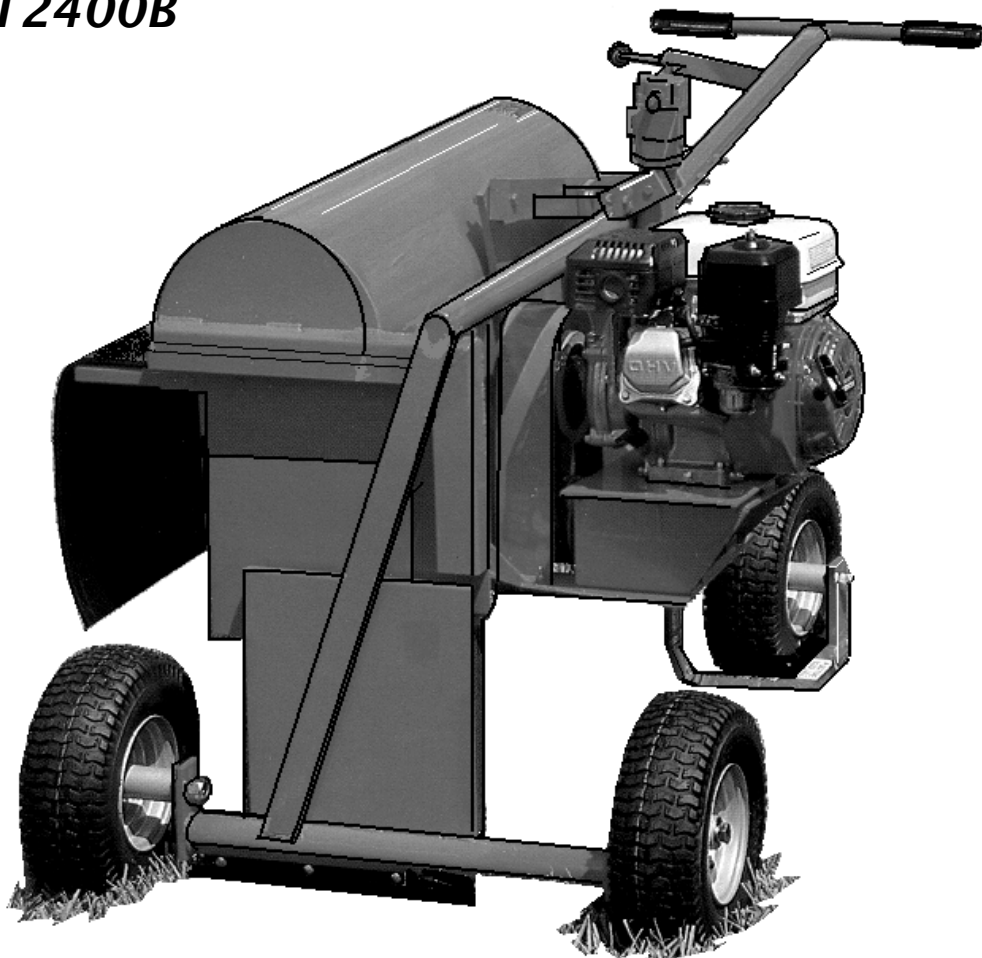

1-800-227-7515

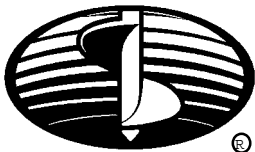

LITTLE BEAVER, INC.

P.O. BOX 840 • 2009 S. HOUSTON • LIVINGSTON, TEXAS 77351

PH# 936/327-3121 • FAX# 936/327-4025

Web: www.littlebeaver.com • E-Mail: sales@littlebeaver.com

MFG. BY: LB EQUIPMENT, INC. - LIVINGSTON, TEXAS USA

CUSTOMER SERVICE

Ph: 800/227-7515 or 936/327-3121 or Fax 936/327-4025

ORDERS...

Place your orders by telephone, fax, or mail. When calling, please have your parts manual handy for reference. Our hours are 8:00 am - 4:30 pm central time, Monday thru Friday. When ordering by mail or fax, include a description and KWIK TRENCH part number for the items you are ordering, your return address, and payment or your authorization for COD shipment.

All orders are shipped UPS where possible. Freight charges will be added to your invoice. Some items are oversize, resulting in a higher shipping cost. Earth Saws are shipped via motor freight due to their weight.

PAYMENT TERMS...

COD, Cash in Advance, Visa, Mastercard, Discover, American Express or NET 30 with approved credit. COD limit for new accounts is \$500.00. Personal or company checks on new accounts will be held until they clear the bank. To eliminate this delay, you may pay by wire transfer or send a certified or cashiers check. For a NET 30 open account, please call or write for a credit application.

SERVICE AND REPAIR...

Your KWIK TRENCH Earth Saw has been designed for user repair with ordinary hand tools. No special tools are required. Consult the appropriate section of the parts manual for instructions.

Service or technical consultation is available, free of charge, from the factory in Livingston, Texas. We will be pleased to help you with any problems or questions. Just write, fax, or call. Our hours are 8:00am - 4:30pm central time, Monday thru Friday.

Factory repair is available. If you return a part to the factory, please include the following information: Your name and return address, a description of the problem and payment or authorization to return the repaired item COD for the repair and shipping charges.

RETURNS...

Please call the factory for a return authorization. This will help to ensure that your parts are handled properly. Include your name and address, customer account #, invoice # under which the returned parts were ordered, and a brief description of the problem with the parts or the reason for returning them. Parts to be considered for warranty must be returned to the factory for inspection within 10 days after receipt of replacement parts. Be sure to prepay the shipping charges, we will not accept collect or COD packages.

LITTLE BEAVER, Inc.
2009 South Houston
P. O. Box 840
Livingston, Texas 77351



SAFETY ALERT SYMBOL 

The symbol shown above is used to call your attention to instructions concerning your personal safety.

WATCH THIS SYMBOL — It points out important safety precautions.

It means — **ATTENTION! BECOME ALERT! YOUR PERSONAL SAFETY IS INVOLVED!**

Read the message that follows and be alert to the possibility of *Personal Injury or Death!*

 **WARNING:** *The Engine Exhaust from this product contains chemicals known to the State of California to cause cancer, birth defects or other reproductive harm.*

1 YEAR LIMITED WARRANTY

For 1 year from purchase, LB EQUIPMENT, INC. will replace for the original purchaser, free of charge, any part or parts, found upon examination by any factory authorized service center, or by the factory at Livingston, Texas, to be defective in material or workmanship or both. If your equipment cannot be repaired, it will be replaced. All transportation charges on parts submitted for replacement under this warranty must be borne by purchaser.

There is no other express warranty.

Implied warranties, including those of merchantability and fitness for a particular purpose, are limited to 1 year from purchase and to the extent permitted by law. Any and all implied warranties are excluded. This is the exclusive remedy and liability for consequential damage under any and all warranties are excluded to the extent exclusion is permitted by law.

*Notice: Engines are warranted by the manufacturer of the engine. See separate engine warranty enclosed.

MACHINE SERIAL NUMBER

The machine serial number for your Kwik Trench Earth Saw is located on the rear shroud. For your convenience, when requiring service of parts information, refer to this number and your model number. Record the model number, engine make, machine serial number and date of purchase in the space provided below:

MODEL NUMBER _____ **ENGINE MAKE** _____

MACHINE SERIAL NUMBER _____ **DATE OF PURCHASE** _____



TABLE OF CONTENTS

OPERATORS MANUAL

Page

O-2	Customer Service Information
O-3	Safety Alert, Warranty and Machine Information
O-4	Table of Contents
O-5	Safety Instructions
O-6	Maintenance and Lubrication, Clutch
O-7	Maintenance and Lubrication, V-Belt
O-8	Maintenance and Lubrication, V-Belt, Cutter Hub, Bearing
O-9	Assembly
O-10	Trenching Instructions

PARTS MANUAL

Page

P-1 & 2	Frame Assembly
P-3	Clutch/Cutter Hub Assembly
P-4	Cutter Wheel Assembly
Inside Back Cover	Torque Information and Conversion Chart



SAFETY INSTRUCTIONS



DANGER: Failure to observe safety instructions and reasonable safety practices can cause Property Damage, Serious Bodily Injury and/or Death. **BE CAREFUL!! WATCH OUT FOR BYSTANDERS!!**



DANGER: NEVER dig trenches where there is a possibility of underground power cables or other hazards. The exact location of underground services must be determined prior to drilling. Inadvertent severing of telephone, fiber optic or CATV transmission cable, or damage to sewer pipe is costly; RUPTURING OF GAS OR WATER LINES CAN CAUSE SERIOUS BODILY INJURY AND/OR DEATH. COMING INTO CONTACT WITH BURIED POWER LINES CAN CAUSE SERIOUS BODILY INJURY, SEVERE BURNS, AND/OR ELECTROCUTION. Call local utility companies or your local "One-Call" number at least 48 hours before digging and have underground utilities marked.



DANGER: NEVER run engine inside building or enclosed area. Exhaust gases contain carbon monoxide, an odorless and deadly poison.



DANGER: KEEP hands and feet away from rotating blades. Serious bodily injury will result.



CAUTION:

1. READ and understand this operator's manual and the operator's manual for the engine. If one is not available, please call or write for a free replacement.
2. NEVER Transport with engine running.
3. NEVER Trench on steep slopes. Trencher may overturn causing bodily injury.
4. NEVER Trench in solid rock or concrete.
5. NEVER Operate with broken teeth, belts or other damaged or missing parts.
6. KEEP Hands, Feet and Clothing away from moving parts while engine is running.
7. KEEP All safety shields and devices in place.
8. MAKE Certain everyone is clear before operating the machine.
9. DO NOT Drop trencher off the back of a vehicle. Trencher's weight can exceed 350 lbs.
10. WEAR SAFETY GLASSES.
11. KEEP Bystanders at least 10 feet away from work area.
12. SHUT OFF Engine and disconnect spark plug wire to adjust, service, refuel or clean the machine. Accidental engine starting is possible by rotating the cutter wheel.
13. AVOID The possibility of spilled fuel causing fire.
14. MAKE Sure when transporting trencher in a vehicle or trailer, it is safely secured with straps or ropes.

NOTICE

It is the responsibility of the contractor, owner and user to maintain and operate the Earth Saw in compliance with operating instructions provided. Observe all listed safety instructions and other reasonable safety practices. LB EQUIPMENT, INC. accepts no responsibility for damages to this machine, and other property damage and/or bodily injury due to careless or improper operations.

LB EQUIPMENT, INC. does not recommend or condone use of replacement engines greater than eight (8) horsepower.

LB EQUIPMENT, INC. does not recommend or condone any unauthorized modifications to the earth saw.

LB EQUIPMENT, INC. reserves the right to make changes in design and changes for improvements upon its product without imposing any obligation upon itself to install the same upon its products theretofore manufactured.

Your operators manual offers recommendations for prolonged and satisfactory service.

Precaution is the best insurance against an accident.



MAINTENANCE and LUBRICATION



DANGER: NEVER run engine inside building or enclosed area. Exhaust gases contain carbon monoxide, an odorless and deadly poison.

Engines are shipped without oil or gasoline. Refer to MANUFACTURER'S INSTRUCTIONS for proper procedures and recommended fluids.

IMPORTANT DO NOT drop the machine off the back of a vehicle, this may cause damage to the body and frame. Machines should always be lifted, ramped or transported by a trailer.

LUBRICATING INSTRUCTIONS:

CHECK crankcase and gearbox oil level before each use.

CHANGE crankcase and gearbox oil as recommended by the manufacturer's instructions.

ADD grease to the pillow block bearings after every 100 hours of use.

CLEAN vertical frame posts and sleeves frequently to prevent binding. Do not use oil base lubricants or grease. Silicone is recommended.



SHUT OFF ENGINE and disconnect spark plug wire to adjust, service, refuel or clean the machine. Accidental engine starting is possible by rotating the cutter wheel.

ALL nuts, fasteners and fittings must be kept properly torqued. After every 25 hours of use the engine nuts and bolts should be checked and tightened, if necessary. Add lock-tight to bolt threads.

AIR FILTER: The air filter needs to be cleaned every 10 hours. More often in dusty dry conditions: Check engine owners manual for further instructions.

Attach a remote air filter with pre-cleaner in serious dusty conditions, this will add to the engine life considerably.

CLUTCH: The slip clutch facings should be changed if the thickness is worn to 1/16" or less, this will maintain the fast digging speed this type of unit can perform. Check every 20-25 hours of use.

ADJUSTMENT: Shoulder bolts must be kept tight. If the clutch wears to the point where stopping the blades will not stall the engine within a few revolutions, tension should be increased by adding a washer under each shoulder bolt, or by replacing the clutch facings.



MAINTENANCE CONT...

V-BELT CARE: V-belts may be the item most overlooked during equipment maintenance, but proper care and maintenance of V-belts and their sheaves (pulleys) can yield great rewards. The nature of V-belts makes preventive maintenance relatively easy. V-belts and sheaves wear gradually and usually give advance warning of failure.

Nonetheless, it is important to recognize the warnings. All belts and sheaves will wear as part of their lifes cycle. As wear occurs, the belts will ride lower in the grooves. A worn belt is, in effect, longer than a new one.

V-belts grip by wedging in the pulley grooves. Belts that are too loose cause slippage, loss of power, loss of speed and rapid wear to both the belt and the sheave. A howl or squeal indicates that the belt is too loose or the load is too heavy.

ALIGNMENT AND TENSION: Check to be sure sheaves are properly aligned because misalignment can cause excessive wear to the belt sidewall. Unusual wear of the belt outer cover is an indication of more serious mechanical trouble. V-belts are designed to operate by making clean, dry surface contact with the sidewall of the sheaves. Inspect belts periodically to assure that they are not contaminated with grease or oil. Don't allow mud, rust or any other foreign matter to build up in sheave grooves. Clean sheaves carefully with a wire brush.

SIGNS OF TROUBLE: Don't install new V-belts without carefully inspecting the sheaves. Focus special attention on these conditions: ~ worn groove sidewalls ~ a shiny sheave groove bottom ~ wobbling sheaves or ~ damaged sheaves. Sheave sidewalls must be perfectly straight because the wedging action of the V-belt is impaired and its gripping power is reduced when the walls are worn or dished out. A shiny sheave groove bottom is an indication that the belt, sheave or both are badly worn and the belt is bottoming in the groove. This condition may first be evident on the smaller sheave.

Sheave wobble may be caused by ~ improper installation on the shaft ~ a worn/damaged bushing ~ a worn/damaged sheave hub or by ~ a bent shaft. Any of these conditions will cause early failure. The wobbling

sheave whips the belt from side to side, subjecting the belt to lateral strain and causing rapid wear to both the sheave and belt. Vibration is another indication of an improperly installed or damaged sheave; however, vibration can also be caused by a damaged belt.

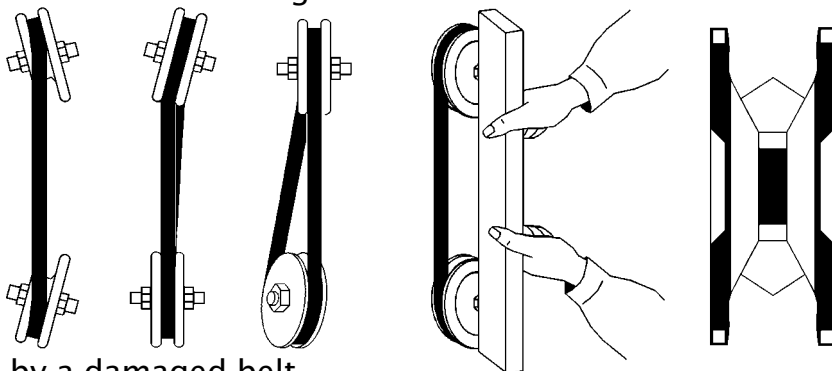

V-BELT CARE CONT...

Check the alignment of the sheaves. The drive and driven shafts should be parallel both horizontally and vertically, and the centers of both sheaves should be in a straight line. Although V-belts can tolerate minor misalignment (About 1/16 inch per 12 inches of shaft center distance), close-to-perfect alignment will prolong belt life.

Set the belt take-up adjustment at its minimum position and place the new belt in the correct position by hand. Never pry belts over the sheave with a screwdriver or other hard object.

All V-belt drives must operate with correct belt tension to provide the optimum wedging action of the belt against the groove sidewalls. Allow a reasonable break in period of a few hours, and then check for proper belt tension. New belts tend to elongate slightly until they are seated in the sheave groove and initial stretch is removed from the belt. Be sure to reinstall all protective guards and shields.

CUTTER HUB:

REMOVING THE CUTTER HUB: Should it ever be necessary to remove the cutter hub, remove the three (3) cap screws and insert two (2) 1/4" - 20 cap screws into the threaded holes in the bushing flange. Tighten the cap screws alternately and evenly so the press against the shoulder of the cutter hub, "jacking" the bushing from the hub.

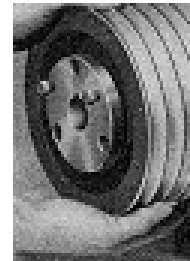

INSTALLING THE CUTTER HUB: To install the cutter hub, assemble the bushing into the cutter hub so that the three (3) counter-bored holes in the bushing line up with the three (3) threaded holes in the cutter hub. Insert the three (3) cap screws through the counter-bored holes into the threaded holes and screw them in finger tight. Slide the cutter hub and bushing on the shaft over the key. Locate the assembly so the blades will clear the base and the guard. Tighten the cap screws in sequence around the circle. Repeat until no further movement can be obtained (approx. 12 ft. lbs.).

BEARINGS:

The nylon bearing (clear collar) must be inserted in the blade with a slight inward bulge. After locating the bearing in the collar of the blade, press the bulge to conform to the contour of the cutter hub.



TRENCHER ASSEMBLY INSTRUCTIONS:

Remove the washers and pins that are on the front axles. Install two (2) front tires with valve stem facing out. Re-install washers & pins. Install rear tire by inserting axle bolt through wheel bearings and swivel. Install and tighten lock nut, leaving a small amount of play in wheel bearings. Tire pressure should be 40 lbs. PSI.

Remove two (2) bolts from open neck of frame. Insert the push handle, re-install bolts.

Attach hand crank and swivel end to manual actuator. Use hand crank to raise shroud and engine all the way.

Follow engine manufacturers start up instructions. Fill crankcase with the recommended oil. Add 30 wt. oil to the 6:1 gear reduction unit til it is 1/3 full.

Follow diagrams on page P-1.2 & 3 to install wear parts and the "Super Blade Plus" or the "Super Extra Rock Blade" on P-4.

Double check all bolts and fasteners. Make sure the blade is properly installed and the shoulder bolts are tightened.

BLADE/TEETH ASSEMBLY:

 **CAUTION:** When removing or installing the blade or when making adjustments on the trencher, the spark plug must be disconnected to prevent accidental starting of the engine.

When determining which teeth are right hand or left hand, stand in the operating position (standing behind the push handle and facing the direction of travel). The teeth that are on the right hand side of the blade are the RIGHT TEETH. The teeth that are on the left hand side of the blade are the LEFT TEETH.

To install new teeth, remove the two (2) shoulder bolts, die springs, friction plate, clutch facings, and the blade. Remove the old teeth from the blade, install the new teeth in the proper order, and remount the blade on the cutter hub.

The width of your trench is determined by the curvature of the tooth. You will have straight teeth, curved in teeth (teeth that curve into the blade) and curved out teeth (teeth that curve away from the blade).

For the KT200B Super Blade Plus (SBP) which has twelve (12) teeth, start placing your teeth on the blade and keep a clock in mind. One o'clock, Two o'clock, etc. Follow the diagram on page P-4 for this model. Standard cut is 2 inches.

The KT200B Super Xtra Rock Teeth (SXRT) only has four (4) "Super Xtra Rock Teeth"



TRENCHER OPERATING INSTRUCTIONS:

Put trencher in position.

Turn fuel on. Use choke when starting engine if necessary.

Allow engine to warm up for 2-3 minutes, then bring engine speed up with the throttle.

Stand behind the push handle and lower trencher by turning the crank handle counter-clockwise to required depth. Keep left hand on the handle for stability.

Push trencher forward to end of your trench.

NOTE: If in hard ground, roots and other problem areas, **DO NOT** attempt to force machine. Allow the cutting blade do the cutting, over pushing may cause the blade to bog-down.

INSTRUCT operator to back off immovable objects to eliminate early teeth breakage.

Raise the blade by turning crank handle clockwise until cutting blade is completely out of the ground.

Stop the engine and turn the fuel off before moving the machine.

DO NOT use disc blade trenchers with missing teeth. If you do, this will increase the possibility of engine vibration.



PARTS INFORMATION

NOTES:

FRAME ASSEMBLY - KT2400B

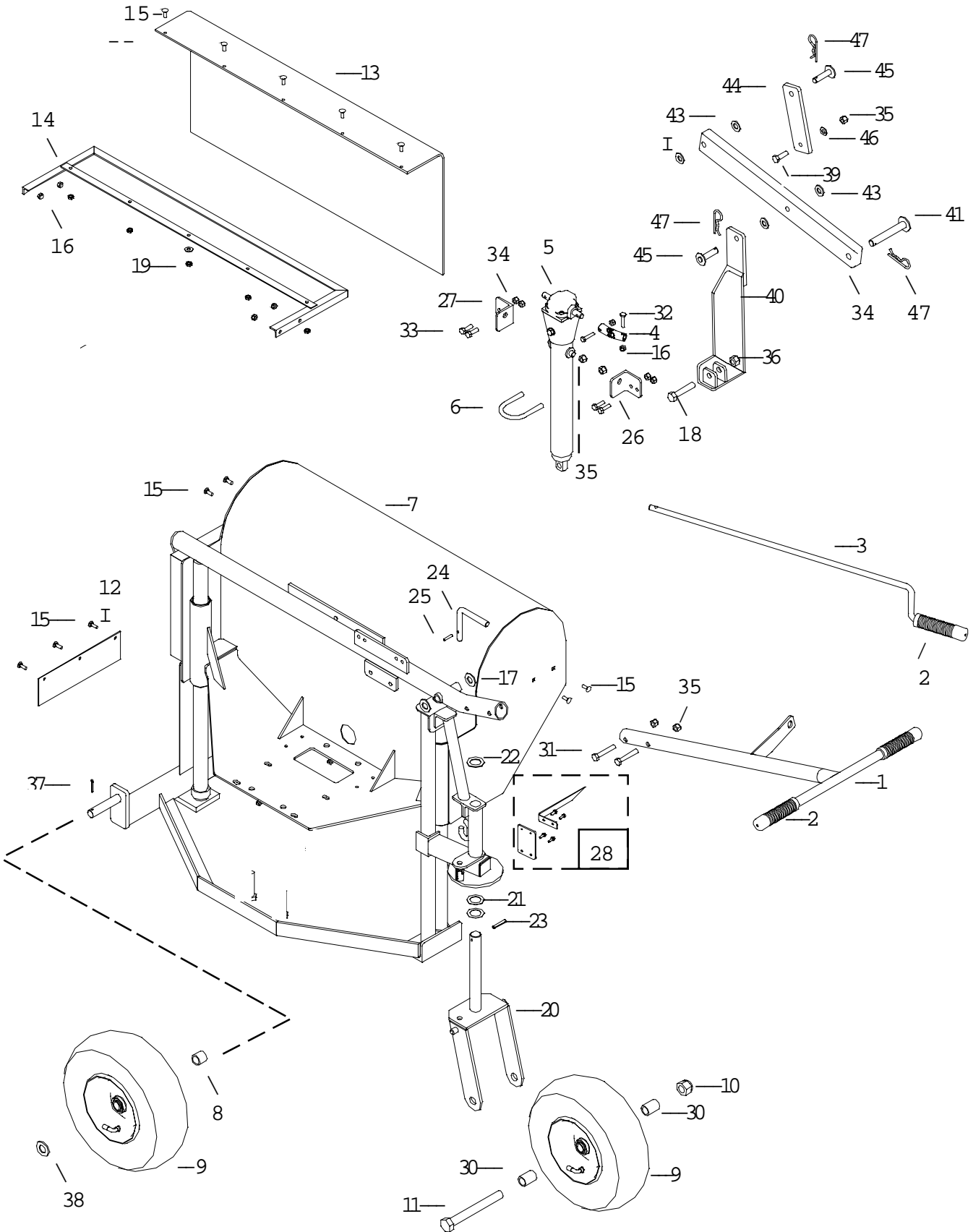

FRAME ASSEMBLY KT2400B

<u>ITEM #</u>	<u>PART #</u>	<u>DESCRIPTION</u>	<u>QTY</u>
1	KT286	Push Handle Assy. (w/ handle grips)	1
2	KT010	Handle Grips	3
3	KT2448	Crank Handle Assy. (w/ handle grip)	1
4	KT006	Swivel, U-Joint	1
5	KT045	Actuator Complete, 8"	1
	KTAH812	Gear Head, Actuator	1
	KT045C	Cylinder, Actuator, 8"	1
	KTAB812	Bevel Housing, Actuator	1
6	KT009	U-Bolt, Actuator, 3/8" NC	1
7	KT2423	Frame Assembly	1
8	35175	Bushing, Front Wheel, 7/8" long	2
9	KT046	Wheel, 12" Pneumatic	3
10	9096	Nut, Hex 3/4 NC Nylon Lock	1
11	KT041	Bolt, Hex, 3/4 x 6-1/2, NC Gr. 5	1
12	KT2416	Skirt, Front	1
13	KT2422	Skirt, Side	1
14	KT2412	Frame, Skirt	1
15	KT021	Bolt, Carriage, 1/4 x 3/4	12
16	30204	Nut, Hex, 1/4 NC, Nylon Lock	6
17	8048	Washer, Flat, 5/8 SAE	2
18	6533	Bolt, Hex, 1/2 x 2-1/2, NC Gr. 5	1
19	9026-KEP	Nut, Hex, 1/4 NC, KEP	8
20	KT250	Swivel, Rear	1
21	36221	Washer, Thrust, 1/32"	2
22	36223	Washer, Thrust, 3/32	1
23	KT040	Roll Pin, 1/4 x 1-1/2	1
24	KT265	Pin, Lock	1
25	KT039	Roll Pin, 3/16 x 1	1
26	KT278	Angle, Actuator Mounting, R.H.	1
27	KT279	Angle, Actuator Mounting, L.H.	1
28	KT2450	Bar, Pointer, (as a weldment)	1
30	KT285	Bushing, Rear Wheel, 1-3/8" long	2
31	KT022	Bolt, Hex, 3/8 x 2-1/4 NC Gr. 5	2
32	4018-1H	Bolt, Hex, 1/4 x 1-1/4 NC Gr. 5	2
33	9024-1	Bolt, Hex, 5/16 x 1 NC Gr. 5	4
34	KT2440	Rocker Arm, Actuator	4
35	30154	Nut, Hex, 3/8 NC, Nylon Lock	4
36	30158	Nut, Hex, 1/2 NC, Nylon Lock	1
37	30163	Cotter Pin, 1/8 x 1	2
38	30164	Washer, Flat, 3/4"	2
39	9027-8	Bolt, Hex 3/8 x 1-1/4 NC Gr. 5	1
40	KT1250	Link, Actuator	1
41	KT1257	Pin	1
43	30153	Washer, Flat 1/2" SAE	4
44	KT2441	Bar, Height Adjustment Linkage	1
45	KT1259	Pin	2
46	3002-B	Washer, Flat, 3/8 Heavy	1
47	9059-1	Hairpin Cotter	3



BELT DRIVE ASSEMBLY KT2400B

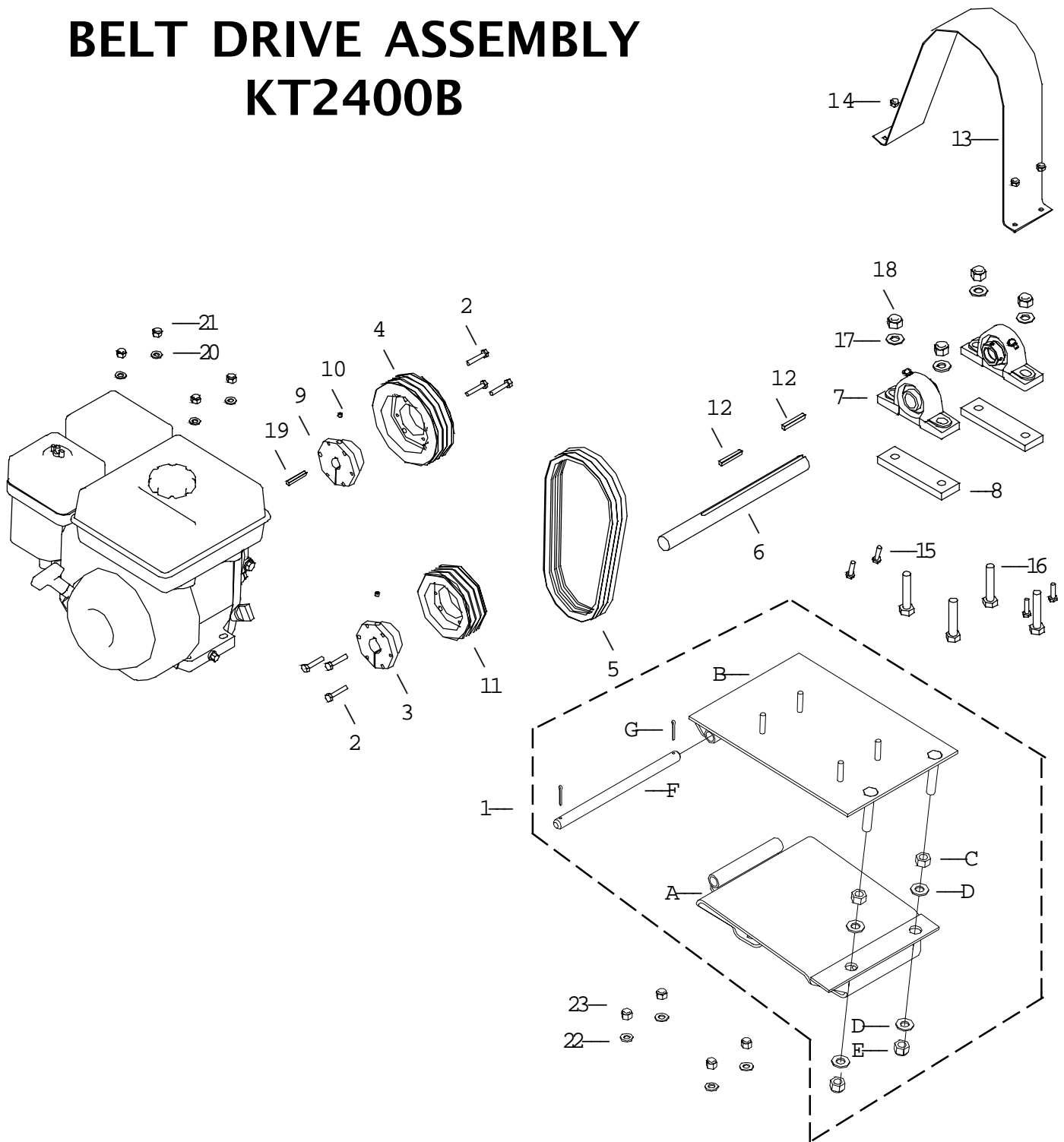

See page O-7 of this manual for Drive Belt information and instructions.

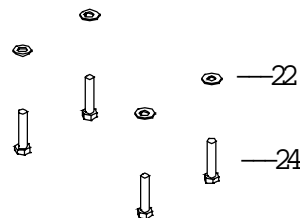

BELT DRIVE ASSEMBLY KT2400B

<u>ITEM #</u>	<u>PART #</u>	<u>DESCRIPTION</u>	<u>QTY</u>
1	KT2420	Top Hat Assy.	1
A	KT2426	Base, Top Hat	1
B	KT2427	Plate, Upper, Top Hat	1
C	30151	Nut, Hex, 1/2" NC	2
D	30153	Washer, Flat, 1/2" SAE	4
E	30158	Nut, Hex, 1/2 NC Nylon Lock	2
F	KT248	Pin, Hinge	1
G	30163	Cotter Pin, 1/8" x 1"	2
2	KT056	Bolt, Hex, 1/4" x 1-3/8" NC Gr. 8 (incl w/ Item #3)	6
3	KT002	Bushing, SDS 1" Pulley w/ Bolts	1
4	KT066	Pulley, 4" Diameter, 3-Belt	2
5	KT4-3V300B	V-Belt, Rubber, 3V, Banded	1
6	KT2421	Bar, PTO Shaft, 1" OD	1
7	KTP205	Bearing, 1" Pillow Block	2
8	KT2446	Bar, Pillow Block	2
9	KT002-3	Bushing, SH 1" Pulley w/ Cap Screws	1
10	9021	Screw, Set, Socket Head, 1/4" x 1/4" NC	2
11	KT065	Pulley, 5.0" Diameter, 3-Belt	1
12	KT230	Key, PTO Shaft	2
13	KT1221	Shroud, Pulley	1
14	9026-KEP	Nut, Hex, 1/4" NC, KEP Lock	4
15	9024-BP	Bolt, Hex, 1/4" x 1" NC Gr. 5	4
16	6533	Bolt, Hex, 1/2" x 2-1/2" Gr. 5	4
17	30153	Washer, Flat, 1/2" SAE	4
18	30158	Nut, Hex, 1/2" NC Nylon Lock	4
19	4081	Key, Engine Shaft	1
20	3002-B	Washer, Flat, 3/8" SAE	4
21	30154	Nut, Hex, 3/8" NC, Nylon Lock	4
22	3002-B	Washer, Flat, 3/8" SAE	8
23	30154	Nut, Hex, 3/8 NC, Nylon Lock	4
24	30295	Bolt, Hex, 3/8 x 1-1/2 NC Gr. 5	4



CLUTCH/CUTTER HUB ASSEMBLY

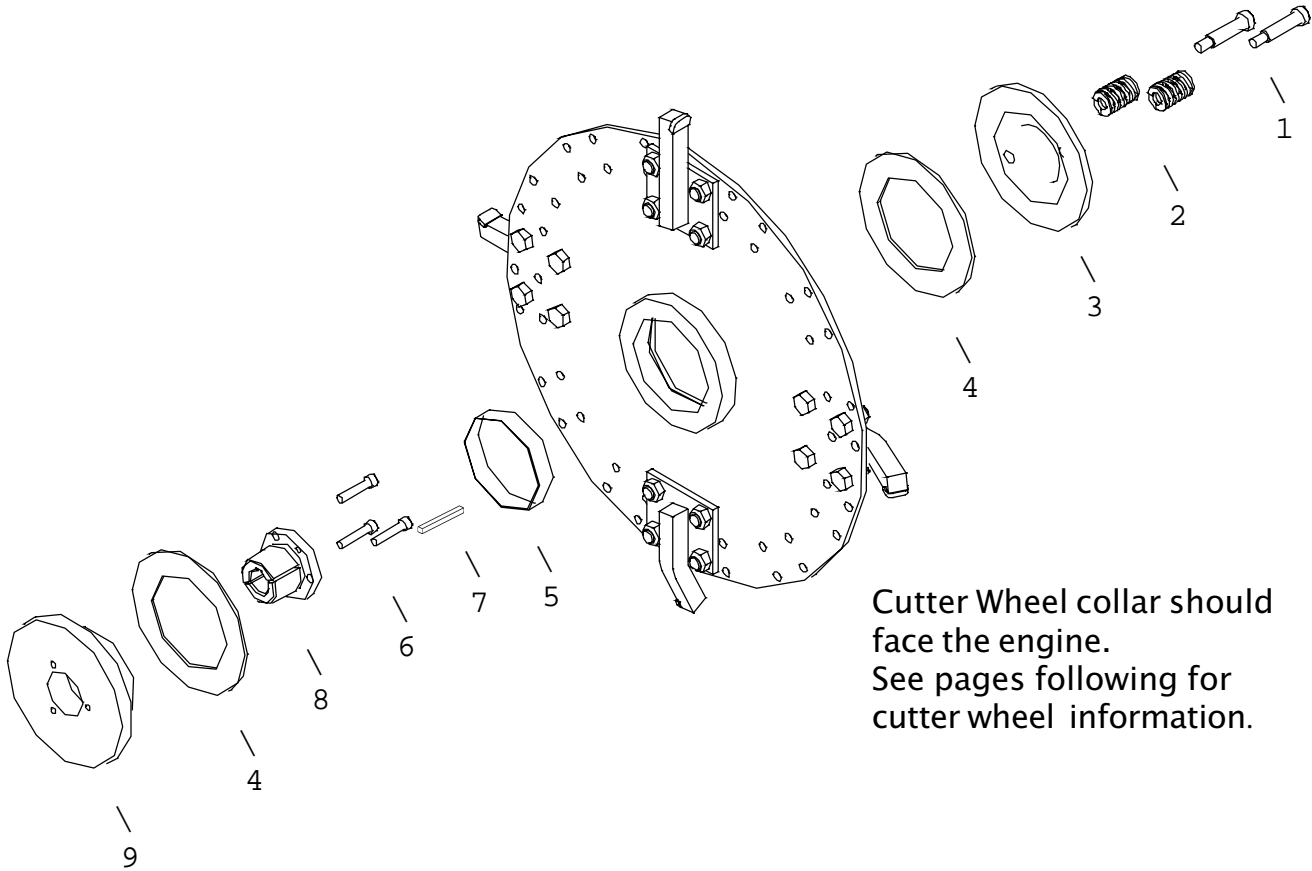

Cutter Wheel collar should face the engine.
See pages following for cutter wheel information.

<u>ITEM #</u>	<u>PART #</u>	<u>DESCRIPTION</u>	<u>QTY</u>
1	KT4-1032	Bolt, Socket Head Shoulder, 1/2 x 1 3/4	2
2	KT4-1031	Spring, Die	2
3	KT4-1017	Friction Plate	1
4	KT4-1029	Clutch Facing	2
5	KT4-1026	Nylon Bearing	1
6	KT4-1040	Cap Screw, Socket Hd., 5/16 x 1 1/2	3
7	KT231	Motor Key	1
8	KT003	Bushing, 1" Bore, P1-1	1
9	KT4-1016	Cutter Hub	1



KT2400B SUPER BLADE PLUS (SBP) BLADE ASSEMBLY (2" digging width)

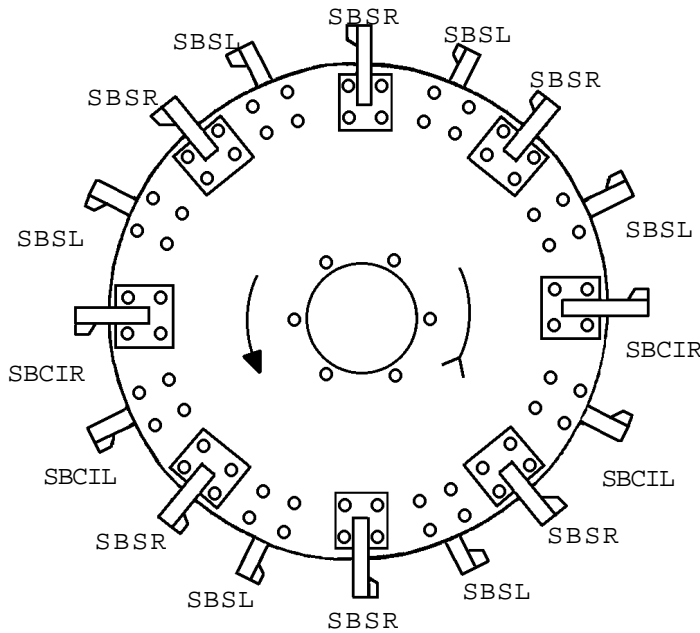

<u>PART #</u>	<u>DESCRIPTION</u>	<u>QTY</u>
KT29S2	Cutter Wheel-2" width	1
KT29S1	Cutter Wheel-1" width	1
KTS241	Teeth Set w/ nuts & bolts	1
KTS242	Teeth Set w/ nuts & bolts	1
KTSBP-SR	Tooth, Straight Right	6
KTSBP-SL	Tooth, Straight Left	6
KTSBP-CIL	Tooth, Curved in Left	2
KTSBP-CIR	Tooth, Curved in Right	2

*To obtain 1" digging width-use 8 Straight teeth & 4 Curved teeth, bolted on same side
call factory for specific details

KT2400B SUPER BLADE PLUS (SBP) BLADE ASSEMBLY (2 1/2" digging width)

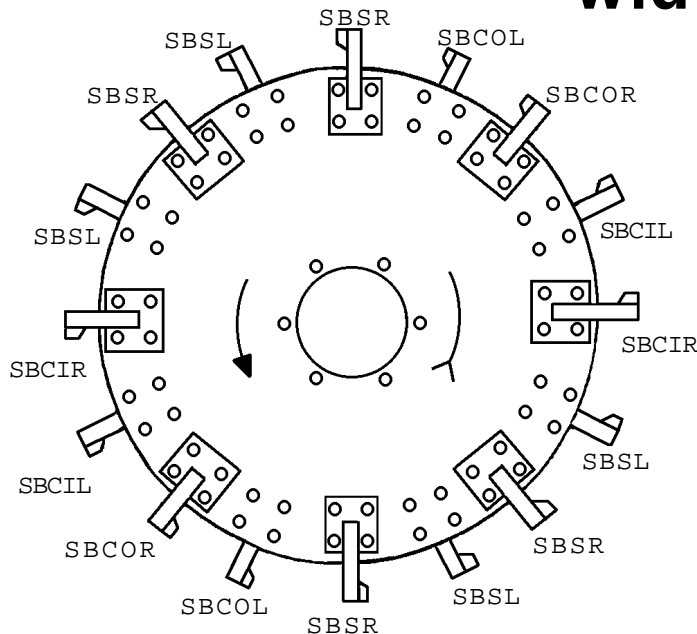

<u>PART #</u>	<u>DESCRIPTION</u>	<u>QTY</u>
KT29S3	Cutter Wheel-2-1/2" width	1
KTS243	Teeth Set w/ nuts & bolts	1
KTSBP-SR	Tooth, Straight Right	4
KTSBP-SL	Tooth, Straight Left	4
KTSBP-CIL	Tooth, Curved in Left	2
KTSBP-CIR	Tooth, Curved in Right	2
KTSBP-COL	Tooth, Curved out Left	2
KTSBP-COR	Tooth, Curved out Right	2



KT2400B SUPER BLADE PLUS (SBP) BLADE ASSEMBLY (3 1/2" digging width)

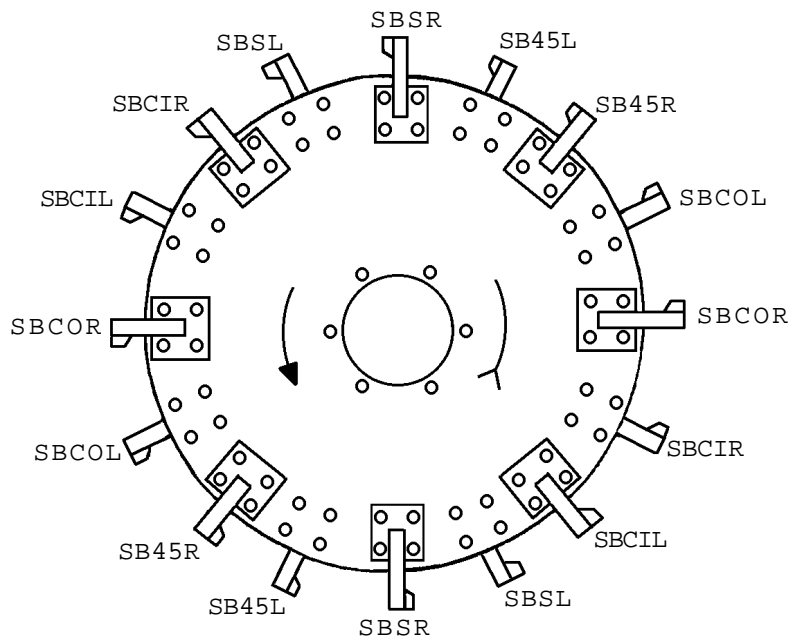

<u>PART #</u>	<u>DESCRIPTION</u>	<u>QTY</u>
KT29S4	Cutter Wheel 3-1/2	1
KTS244	Teeth Set w/ nuts & bolts	1
KTSBP-SR	Tooth, Straight Right	2
KTSBP-SL	Tooth, Straight Left	2
KTSBP-CIL	Tooth, Curved in Left	2
KTSBP-CIR	Tooth, Curved in Right	2
KTSBP-COL	Tooth, Curved out Left	2
KTSBP-COR	Tooth, Curved out Right	2
KTSBP-45L	Tooth, 45 degree Left	2
KTSBP-45R	Tooth, 45 degree Right	2



KT2400B SUPER XTRA ROCK (SXRT) BLADE ASSEMBLY (2"-3" digging width)

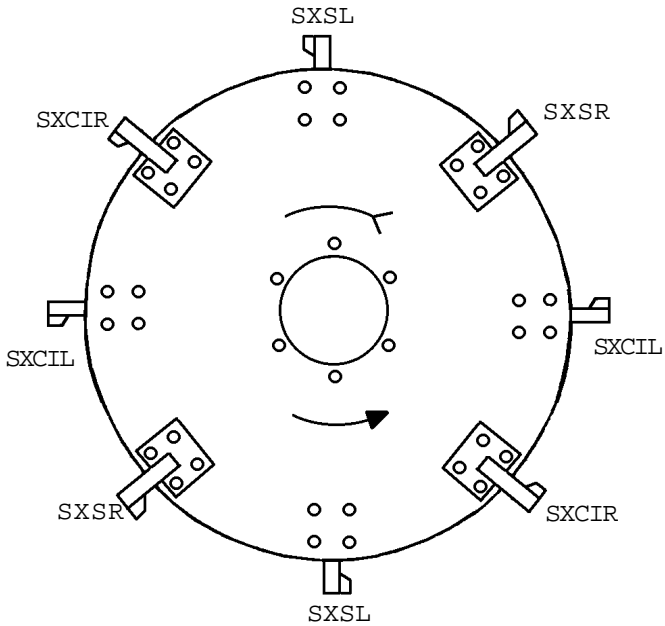

ROTATION: Counter-Clockwise

<u>PART #</u>	<u>DESCRIPTION</u>	<u>QTY</u>
KT29R2	Cutter Wheel-2" width	1
KTR242	Teeth Set w/ nuts & bolts	1
KTSXRT-SR	Tooth, Straight Right	2
KTSXRT-SL	Tooth, Straight Left	2
KTSXRT-CIL	Tooth, Curved in Left	2
KTSXRT-CIR	Tooth, Curved in Right	2

KT2400B SUPER XTRA ROCK (SXRT) BLADE ASSEMBLY (4"-5" digging width)

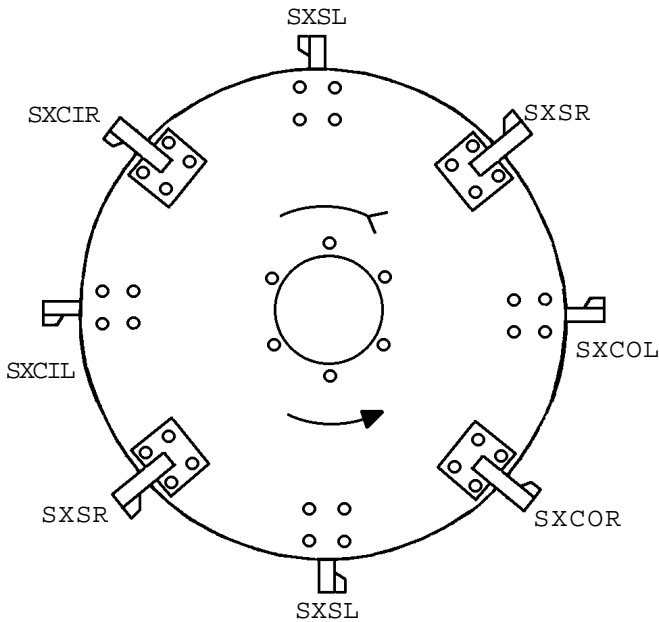

ROTATION: Counter-Clockwise

<u>PART #</u>	<u>DESCRIPTION</u>	<u>QTY</u>
KT29R4	Cutter Wheel-4" width	1
KTR244	Teeth Set w/ nuts & bolts	1
KTSXRT-SR	Tooth, Straight Right	2
KTSXRT-SL	Tooth, Straight Left	2
KTSXRT-CIL	Tooth, Curved in Left	1
KTSXRT-CIR	Tooth, Curved in Right	1
KTSXRT-COL	Tooth, Curved out Left	1
KTSXRT-COR	Tooth, Curved out Right	1



BELT REPLACEMENT INSTRUCTIONS

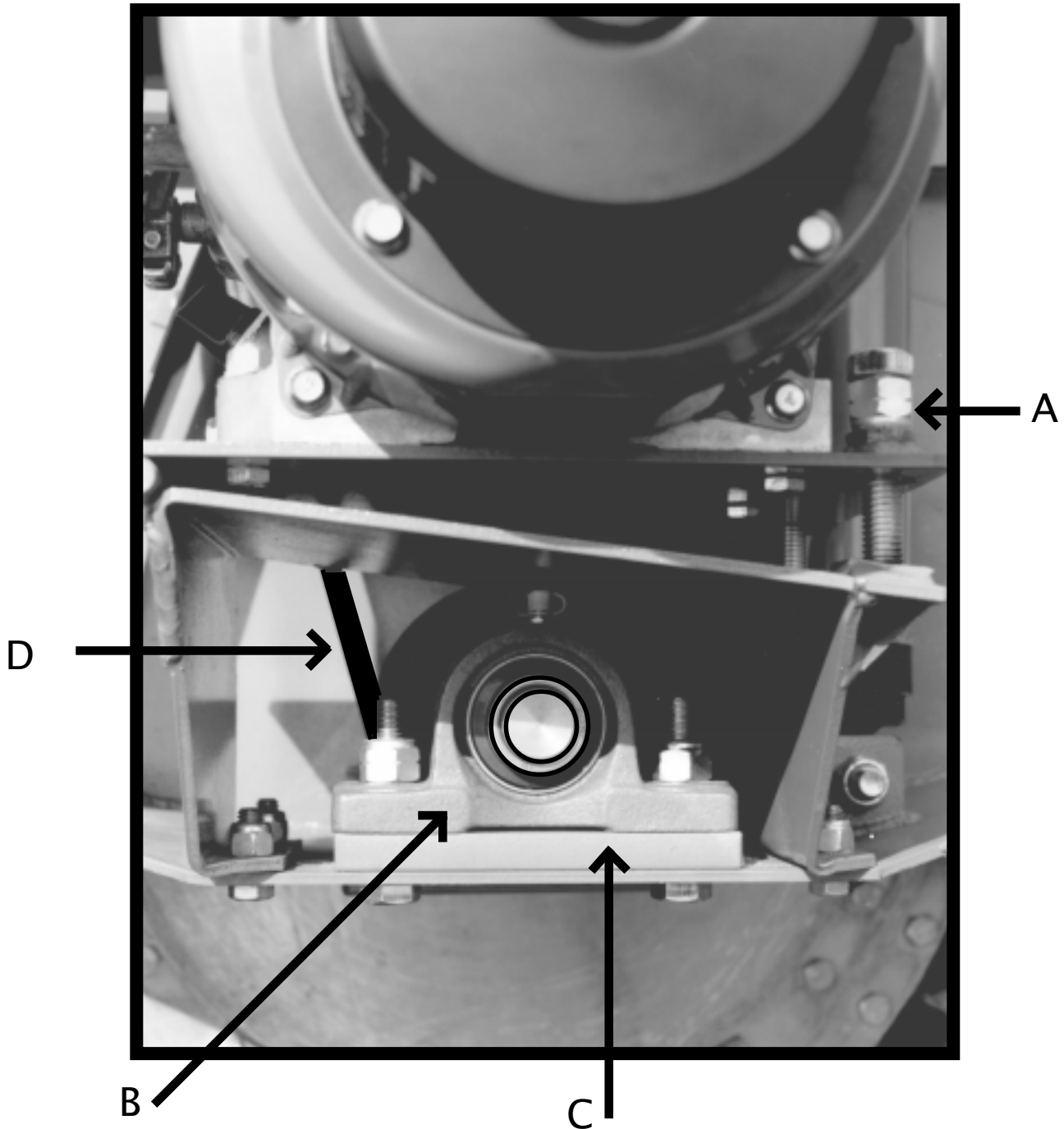

1. Reduce Belt Tension by loosening nuts on belt adjustment plate. (A)
2. Remove two nuts & bolts from pillow block bearing under the engine(B) and remove spacer(C).
3. Slip the new belt over and under pillow block to the belt pulleys. Note: If one belt needs replaced, all three belts need to be replaced at the same time to assure maximum performance.
4. When belts are in place, replace spacer (C) and re-tighten belt adjustment nuts until there is little slack in the belts (D).
5. If the digger blade slips when trenching, add more tension to the belts. However, over tensioning will cause premature belt and/or bearing failure.

**THINK
SAFETY
FIRST**

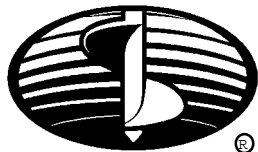

LITTLE BEAVER, INC.

P.O. BOX 840 • LIVINGSTON, TEXAS 77351

PH# 936/327-3121 • FAX# 936/327-4025

Web: www.littlebeaver.com • E-Mail: sales@littlebeaver.com