

LITTLE BEAVER[®]

EARTH DRILLS & AUGERS

BIG BEAVER POWER MAST

(BIGBVR / BIGBVRXL)



OPERATOR'S MANUAL

WITH MAINTENANCE AND PARTS INFORMATION

1-800-227-7515

LITTLE BEAVER, INC.

P.O. BOX 840 • LIVINGSTON, TEXAS 77351

PHONE 936/327-3121 • FAX 936/327-4025

Web: www.littlebeaver.com • E-Mail: sales@littlebeaver.com

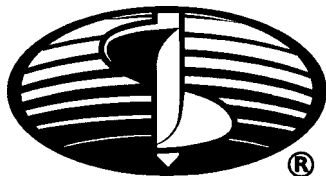

0406

MFG. BY: LITTLE BEAVER, INC. - LIVINGSTON, TEXAS USA

CUSTOMER SERVICE

Ph: 800/227-7515 or 936/327-3121 or Fax 936/327-4025

ORDERS...

Place your orders by telephone, fax, or mail. When calling, please have your parts manual handy for reference. Our hours are 8:00 am - 4:30 pm central time, Monday thru Friday. When ordering by mail or fax, include a description and LITTLE BEAVER part number for the items you are ordering, your return address, and payment or your authorization for COD shipment. All orders are shipped UPS where possible. Freight charges will be added to your invoice. Some items are oversize, resulting in a higher shipping cost. Power units and larger augers are shipped via motor freight due to their weight.

PAYMENT TERMS...

COD, Cash in Advance, Visa, Mastercard or NET 30 with approved credit. COD limit for new accounts is \$500.00. Personal or company checks on new accounts will be held until they clear the bank. To eliminate this delay, you may pay by wire transfer or send a certified or cashiers check. For a NET 30 open account, please call or write for a credit application.

SERVICE AND REPAIR...

Your LITTLE BEAVER Big Beaver Power Mast Earth Drill has been designed for user repair with ordinary hand tools. No special tools are required. Consult the appropriate section of the parts manual for instructions.

Service or technical consultation is available, free of charge, from the factory in Livingston, Texas. We will be pleased to help you with any problems or questions. Just write, fax, or call. Our hours are 8:00am - 4:30pm central time, Monday thru Friday.

Factory repair is available. If you return a part to the factory, please include the following information: Your name and return address, a description of the problem and payment or authorization to return the repaired item COD for the repair and shipping charges.

RETURNS...

Please call the factory for a return authorization. This will help to ensure that your parts are handled properly. Include your name and address, customer account #, invoice # under which the returned parts were ordered, and a brief description of the problem with the parts or the reason for returning them. Parts to be considered for warranty must be returned to the factory for inspection within 10 days after receipt of replacement parts. Be sure to prepay the shipping charges, we will not accept collect or COD packages.

Our mailing address...

LITTLE BEAVER, Inc.
P. O. Box 840
Livingston, Texas 77351



SAFETY ALERT SYMBOL 

The symbol shown above is used to call your attention to instructions concerning your personal safety. **WATCH THIS SYMBOL** — It points out important safety precautions. It means — **ATTENTION! BECOME ALERT! YOUR PERSONAL SAFETY IS INVOLVED!**

Read the message that follows and be alert to the possibility of *Personal Injury or Death!*

1 YEAR LIMITED WARRANTY

For 1 year from purchase, LITTLE BEAVER, INC. will replace for the original purchaser, free of charge, any part or parts, found upon examination by any factory authorized service center, or by the factory at Livingston, Texas, to be defective in material or workmanship or both. If your equipment can not be repaired, it will be replaced. All transportation charges on parts submitted for replacement under this warranty must be borne by purchaser.

There is no other express warranty.

Implied warranties, including those of merchantability and fitness for a particular purpose, are limited to 1 year from purchase and to the extent permitted by law. Any and all implied warranties are excluded. This is the exclusive remedy and liability for consequential damages under any and all warranties are excluded to the extent exclusion is permitted by law.

*Notice: Engines are warranted by the manufacturer of the engine. See separate engine warranty enclosed.

MACHINE SERIAL NUMBER

The machine serial number for your Big Beaver Power Mast is located on the top rear of the drill mast. For your convenience, when requiring service or parts information, refer to this number and your model number. Record the model number, machine serial number and date of purchase in the space provided below:

MODEL NUMBER _____

MACHINE SERIAL NUMBER _____

DATE OF PURCHASE _____



TABLE OF CONTENTS

OPERATORS MANUAL

Page #	
O-2	Service Information
O-3	Safety Alert, Warranty and Machine Information
O-4	Table of Contents
O-5	Safety Instructions
O-6 & 7	Maintenance and Lubrication
O-8	Troubleshooting
O-9 & 10	Operating Instructions
O-11 & 12	Drilling Procedure
O-13	Auger, Blade & Point Information

PARTS MANUAL

P-1 & 2	Drill Head and Auger Tools
P-3 & 4	Valves and Mounting
P-5 & 6	Auger Lift Drive
P-7 & 8	Drill Frame Assembly
P-9 & 10	Mobile Frame Assembly
P-11	Torque Tube and Stay
P-12	Safety Sign & Decals
Inside Back Cover	Torque Information



SAFETY INSTRUCTIONS



WARNING: Failure to observe safety instructions and reasonable safety practices can cause Property Damage, Serious Bodily Injury and/or Death. BE CAREFUL!! WATCH OUT FOR BYSTANDERS!!



DANGER: NEVER drill holes where there is a possibility of underground power cables or other hazards. The exact location of underground services must be determined prior to drilling. Inadvertent severing of telephone, fiber optic or CATV transmission cable, or damage to sewer pipe is costly; RUPTURING OF GAS OR WATER LINES CAN CAUSE SERIOUS BODILY INJURY AND/OR DEATH. COMING INTO CONTACT WITH BURIED POWER LINES CAN CAUSE SERIOUS BODILY INJURY, SEVERE BURNS, AND/OR ELECTROCUTION. Call local utility companies or your local "One-Call" number at least 48 hours before digging and have underground utilities marked.



DANGER: NEVER run engine inside building or enclosed area. Exhaust gases contain carbon monoxide, an odorless and deadly poison.



DANGER: Keep the machine and drilling tools away from overhead electric wires and devices. Electrocution can occur without direct contact. Failure to keep away will result in Serious Injury and/or Death.



WARNING: Never use hands to search for leaks. Instead, use a piece of cardboard or wood. Escaping hydraulic fluid under pressure can have sufficient force to penetrate the skin, causing serious injury. Before disconnecting lines, be sure to relieve pressure. Before applying pressure, be sure connections are tight and fittings and hoses are not damaged.

If injured by escaping fluid, see a doctor at once. Serious infection and/or reaction can develop if proper medical treatment is not administered immediately.



CAUTION:

1. Read and understand this operator's manual before operating.
2. Read and understand the operator's manual for the Hydraulic Power Source.
3. Keep all safety shields and devices in place.
4. Make sure everyone is clear before operating.
5. Keep hands, feet and clothing away from moving parts.
6. Shut off engine to adjust, service, clean or re-fuel.
7. Relieve hydraulic pressure before disconnecting hoses or fittings.
8. Never operate drill without correctly installing torque tube.
9. Lower drill head before moving the machine.
10. Never operate drill with damaged or missing parts.
11. Do not leave machine unattended with engine running.
12. Wear safety glasses.

NOTICE

It is the responsibility of the contractor, owner and user to maintain and operate the Big Beaver Power Mast in compliance with operating instructions provided. Observe all listed safety instructions and other reasonable safety practices. LITTLE BEAVER, INC. accepts no responsibility for damages to this machine, and other property damage and/or bodily injury due to careless or improper operations.

LITTLE BEAVER, INC. does not recommend or condone any unauthorized modifications to the Big Beaver Power Mast.

LITTLE BEAVER, INC. reserves the right to make changes in design and changes for improvements upon its product without imposing any obligation upon itself to install the same upon its products theretofore manufactured.

Your operator's manual offers recommendations for prolonged and satisfactory service.



MAINTENANCE AND LUBRICATION



CAUTION: Shut off power to adjust, service, or clean the machine.



CAUTION: Keep all safety shields and devices in place.

IMPORTANT: Keep all nuts, fasteners, and fittings properly torqued. Refer to torque chart (inside back cover) for proper assembly torque.



WARNING: NEVER use hands to search for leaks, instead, use a piece of cardboard or wood. Escaping hydraulic fluid under pressure can have sufficient force to penetrate the skin, causing serious injury. Before disconnecting lines, be sure to relieve pressure. Before applying pressure, be sure connections are tight and fittings and hoses are not damaged.

If injured by escaping fluid, see a doctor at once. Serious infection and/or reaction can develop if proper medical treatment is not administered immediately.

HYDRAULIC OIL LEAKAGE: If any hydraulic oil leakage is encountered, check and properly tighten the associated fitting. (Refer to torque chart for proper assembly torque). If the leakage persists, it may be necessary to replace the associated fitting or hose assembly. If one of the quick disconnect fittings is the source of leakage, the O-Ring, Part #35262 should be replaced.

IMPORTANT: All nuts, fasteners, and fittings must be kept tightened. Refer to Torque Chart (inside back cover) for proper assembly torque.

RECOMMENDED GREASE: Exxon Unirex N-2

NLGI No. 2 Grade

Available in 14 ounce cartridges.

Individually or in case of 10.

ORDER PART #9070



DRIVE SHAFT:

The drive shaft and drive nut should be greased every 8 hours of operation using the recommended grease. Apply the grease through the grease fitting which is accessible from the top front of the drill head. It may also be necessary to apply grease directly to the shaft in order to maintain a film of grease over the entire shaft. After grease has been applied, run the drill head up and down to work the grease over the entire shaft.

BASE THRUST BEARING:

The base thrust bearing should be greased every 40 hours of operation using the recommended grease. Apply 1-2 pumps of grease through the grease fitting which is located at the bottom of the drill mast.

FLANGE BEARINGS:

The flange bearings, at each end of the drive shaft, should be greased every 80 hours of operation using the recommended grease.

DRIVE CHAIN:

The drive chain should be checked for tightness every 40 hours of operation and lubricated if necessary. The cover plate, at the top of the drill mast, must be removed to access the drive chain. Loosen the pivot and slot bolts and the move feed drive motor back to remove slack, then re-tighten the bolts. If the chain becomes dry, lubricate the chain with a heavy weight oil or grease. Be sure to replace the cover plate.

IMPORTANT: Check the base of the drill mast periodically, around the drive shaft, to determine if dirt build-up is present. Clean away the dirt build-up if present. Rear and side plates at the base may be removed to aid the removal of dirt if necessary. Be sure to replace the rear and side plates.



CAUTION: NEVER operate drill with damaged or missing parts.



MAKE SURE EVERYONE IS CLEAR BEFORE OPERATING.





TROUBLE SHOOTING

TROUBLE	CAUSE
Can not connect or disconnect auger.	<ol style="list-style-type: none">1.) Foreign matter clogging adaptor.2.) Pin is bent.3.) Adaptor is bent.
Auger turns too slowly and will not dig.	<ol style="list-style-type: none">1.) Binding caused by misalignment of auger with drive adaptor. Realign the auger with the drive adaptor.2.) Downward feed rate too fast for soil conditions. Allow soil to work up to the surface to prevent screwing the auger into the ground and overloading.3.) Underground obstruction encountered. It may be necessary to investigate before proceeding.
Auger with extension(s) will not dig.	<ol style="list-style-type: none">1.) Binding caused by misalignment of auger and extension (s) with drive adaptor. Realign the drive adaptor with the auger and extension(s).2.) Friction between sides of hole and flighting. Water may be added to hole to reduce friction.3.) Auger or extension bent or broken.
Auger turns but will not dig.	<ol style="list-style-type: none">1.) Foreign matter collected around point.2.) Point or blade is dull.3.) Use carbide blade for hard pan soil.
Unable to raise auger and extension(s) from hole.	<ol style="list-style-type: none">1.) Drill mast moved out of parallel with auger and extension(s) causing binding. Keep the drill mast parallel with auger and extension(s).2.) Binding on the sides of the hole. It may be beneficial to rotate (forward) the auger and extension(s) as they are raised.3.) The auger lodged under large root, rock or other obstruction. Rotate (reverse) the auger slightly to dislodge the auger.
Hoses and valves over-heat.	<ol style="list-style-type: none">1.) Hydraulic oil level in power source is too low.2.) Cooling fan on power source has malfunctioned.



OPERATING INSTRUCTIONS:

 **DANGER: NEVER** drill holes where there is a possibility of underground power cables or other hazards. The exact location of underground services must be determined prior to drilling. Inadvertent severing of telephone, fiber optic or CATV transmission cable, or damage to sewer pipe is costly; RUPTURING OF GAS OR WATER LINES CAN CAUSE SERIOUS BODILY INJURY AND/OR DEATH. COMING INTO CONTACT WITH BURIED POWER LINES CAN CAUSE SERIOUS BODILY INJURY, SEVERE BURNS, AND/OR ELECTROCUTION. Call local utility companies or your local "One-Call" number at least 48 hours before digging and have underground utilities marked.

 **DANGER: NEVER** run engine inside building or enclosed area. Exhaust gases contain carbon monoxide, an odorless and deadly poison.

PRE-DRILLING SETUP:

The following instructions will ease the maneuverability of the Big Beaver Drill as shown in Figure 1.

- 1.) Drill head should be in lowered position.
- 2.) Drill mast should be adjusted near vertical.
- 3.) Maintain proper tire inflation pressure.

IMPORTANT: Additional assistance may be required when moving the drill on side hills or over obstructions to avoid overturning the drill.

Note: It may be necessary to detach the base frame feet in order to provide clearance through narrow openings.

Set the drill upright, into the desired position to drill the hole.

Note: It may be necessary to detach the base frame feet in order to position the drill in a corner. However, the base frame feet should always remain attached, when possible, to provide stability.

Adjust the drill angle by loosening the set bolt on the side brace and turning the angle adjustment crank. The drill mast may be adjusted from 0° to 15° from vertical. Tighten the set bolt on the side brace after adjustment is complete. (See Figure 2)

- 1 - Set bolt
- 2 - Side brace
- 3 - Angle adjustment crank
- 4 - Torque tube connection points



Figure 1
Transporting the Big Beaver Drill

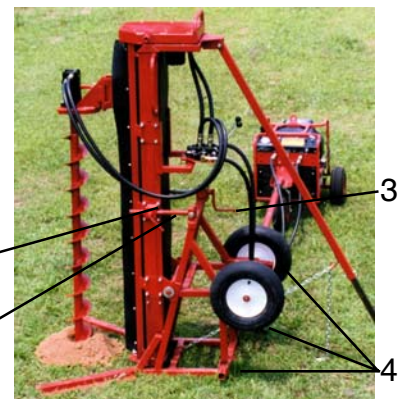

Figure 2



Extend the back stay and pin the center (third) hole (or the nearest hole which allows clearance from obstructions). Next, attach the chain to the hook on the back stay by pushing the top of the mast forward slightly and hooking a link in the chain which will allow the rear of the base frame to be slightly off the ground with the chain taut. (See Figure 3)

- 1 - Back Stay
- 2 - 3/8" Dia. Snap Pin
- 3 - Chain Taut

NOTE: It may be necessary to re-adjust the drill angle slightly after the back stay has been properly positioned.

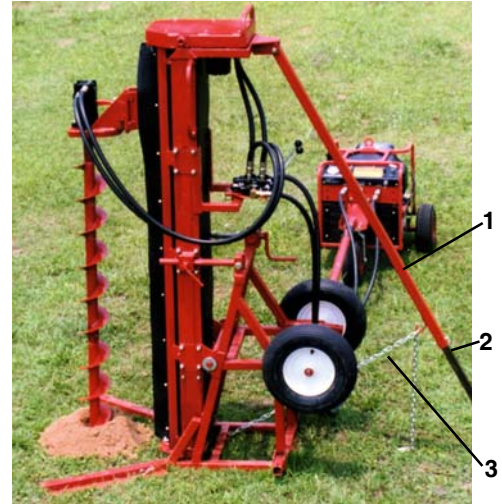

Figure 3



CAUTION: Never operate drill without correctly installing torque tube.

Connect the torque tube between the drill frame and the power source (or other secure anchor point). Be aware that the torque tube can be connected to 3 different points on the drill frame with or without the 45 adaptor, which allows 9 different torque tube positions. (See Figure 2) Use the torque tube position which is the most convenient and allows clearance from obstructions.

Pivot the valve plate to one of three positions (either side or straight back) by removing the snap pin and pivoting the plate to the desired position and re-installing the snap pin. (See Figure 4) Use the valve plate position which is the most convenient and allows clearance from obstructions.

Connect the hoses to the hydraulic power source.

IMPORTANT: The pressure hose must enter at the left-hand side of the valves.



Figure 4
Valve plate in side position



CAUTION: Read and understand the operator's manual for the hydraulic power source you are using.



DRILL HEAD CONTROLS:

The left-hand valve controls the auger drive motor and the right-hand valve controls the feed drive motor.

Pull back the left-hand valve lever for forward (clockwise) auger rotation and push forward the left-hand valve lever for reverse (counterclockwise) auger rotation.

NOTE: Reverse rotation of the auger should only be used in limited circumstances, such as dislodging the auger from large roots, rocks and other underground obstructions.

Pull back the right-hand valve lever to lower the drill head and push forward the right-hand valve lever to raise the drill head.

NOTE: The farther the valve lever is moved, the faster the motor will rotate. Therefore, fine control can be achieved by slightly moving the valve lever.

DRILLING PROCEDURE:



CAUTION: Keep all safety shields and devices in place.



CAUTION: Make certain everyone is clear before operating.

Raise the drill head and attach the auger to the auger motor drive adaptor. Lower the auger bit to the ground and apply pressure. Begin rotating the auger forward while maintaining pressure on the bit.

IMPORTANT: Make sure the auger is started in line with the auger motor shaft to avoid binding.

After the auger is started, operate the auger drive motor at full speed while maintaining downward pressure with the feed drive motor.

NOTE: When drilling in soft soil, allow the soil to work up to the surface without forcefully screwing the auger into the ground and overloading the auger.

If greater hole depths are required, auger extensions may be used with the auger. After the auger has reached its maximum depth, stop the auger and disconnect the drive adaptor from the auger which remains in the hole. Raise the drill head and connect the auger extension to the auger. Lower the drill head to connect the drive adaptor to the auger extension and continue to drill the hole. Repeat this procedure until the desired depth is reached.



 **CAUTION:** Make certain everyone is clear when making connections and operating the drill.

 **CAUTION:** Keep hands, feet and clothing away from moving parts.

When the desired depth is reached, raise the drill head completely. Insert the auger fork around the auger (or extension) barrel approximately 6-8 inches below the top of the auger (or extension). Be sure the base of the auger fork is against the auger (or extension) barrel (not the flighting) and the ends of the auger fork are over the base frame feet.

NOTE: It may be necessary to rotate the auger (or extension) slightly to position the auger fork correctly.

Lower the drill head until the weight of the auger and extension(s) are resting on the auger fork. Disconnect the auger extension just above the auger fork. Raise the drill head and disconnect the auger extension from the drive adaptor. Next, connect the retriever ring to the drive adaptor. Lower the drill head and retrieve the remaining auger and extension(s) using the retriever ring and the 9 inch long pin. Repeat this procedure until the auger and extension(s) have been removed from the hole.

NOTE: It may be beneficial to rotate (forward) the auger and extension(s) when raising out of the hole to remove soil from flighting and ease removal. However, do not rotate with the auger fork in place.

NOTE: The auger and extension(s) may also be manually removed from the hole by unlatching and pivoting the drill head clear. (See Figure 5) However, this procedure should only be used with sufficient overhead clearance and when lifting requirements are not prohibitive.



Figure 5
Drill head swing clear

 **DANGER: Keep** the machine and drilling tools away from overhead electric wires and devices. Electrocutation can occur without direct contact. Failure to keep away will result in serious injury and/or death.

 **CAUTION: Keep** your back as vertical as possible by bending the legs, as required, when lifting to avoid injury.



! **WHEN WORKING WITH CUTTING BLADE,** Point and Auger Flighting, be careful not to be cut by sharp edges.

STANDARD CUTTING BLADE & POINT

Check the cutting blade (Item A, Figure 6) on the auger frequently. If it becomes dull, it may be reversed to use the other cutting edge. If the outside of the blade wears even with the auger flighting, replace the blade or rebuild it with a hardsurfacing rod. This is very important to reduce auger flighting wear and damage. The point (Item B, Figure 6) should be replaced when it loses its cutting shape.

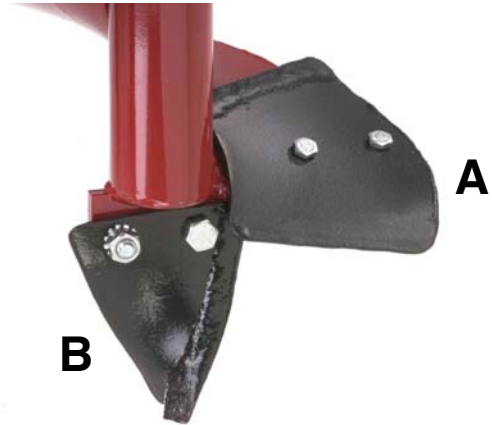
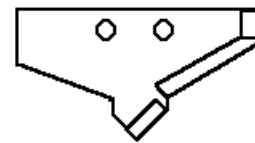

Figure 6

OPTIONAL CARBIDE BLADE:

An optional carbide blade is available for auger sizes 1-1/2" thru 12". It is designed for use in smooth hard-pan soils, asphalt or frost. It is not recommended for use in rocky soils. The 4" thru 12" carbide blade bolts on to the auger in place of the standard point. The standard blade is not used.



(4"-12")

Mount the blade to the auger using the included 3/8" x 1-1/4" bolts and nylon lock-nuts. Use a framing square to carefully align the blade at 90 degrees to the auger. Tighten the nuts slowly until snug, then re-check alignment and adjust if necessary. Torque the bolts to 45 ft. lbs.

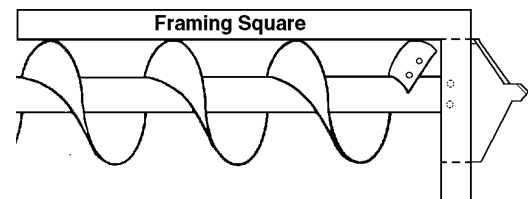

! **CAUTION:** If the blade is not installed properly, mis-alignment may cause the auger to vibrate and "walk" in use.



DRILL HEAD AND AUGER TOOLS

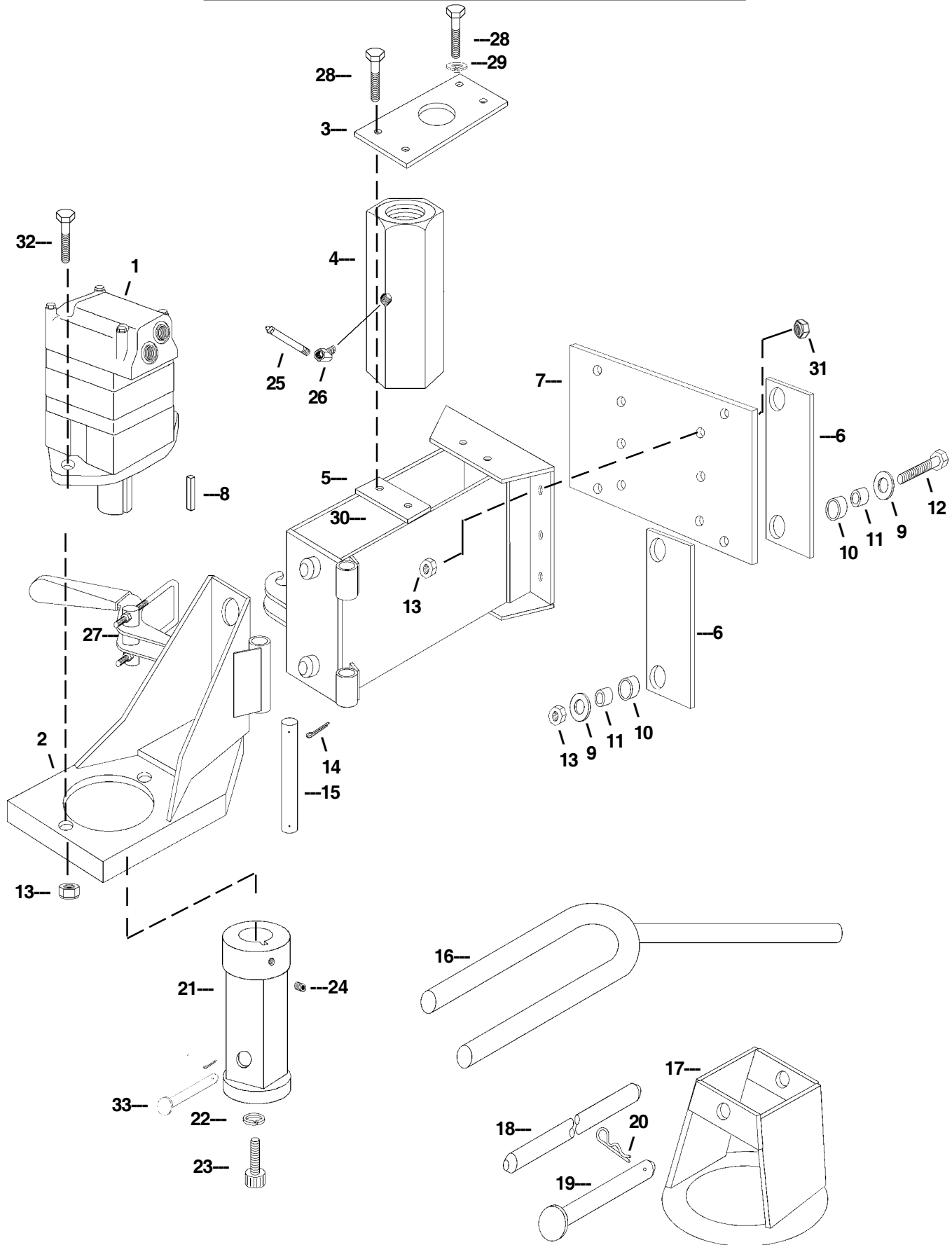

DRILL HEAD AND AUGER TOOLS

ITEM #	PART #	DESCRIPTION	QTY
1	30191-S6	Motor, Hyd. Auger Drive (11.9 cu. in. rev.)	1
	30191-S4	Motor, Hyd. Auger Drive (14.9 cu. in. rev.)	1
	(not shown) 36342	Seal Kit, 2000 Series Motors w/suffix -002/-005	1
	(not shown) 36347	Seal Kit, 2000 Series Motors w/suffix -006	1
2	36055	Drill Head, Inc. Clamp Assy.	1
3	36075	Plate, Nut Cap	1
4	36090	Nut, Lift Drive	1
5	36040	Base, Head	1
6	36080	Pad, Slide Friction	4
7	36035	Plate, Drill Head Mounting	1
8	36054	Key, 5/16 Square x 1-1/4	1
9	30153	Washer, Flat, 1/2"	8
10	36085	Bushing, Roller	8
11	36086	Bushing, Roller Guide	8
12	6533	Bolt, 1/2 x 2-1/2	4
13	30158	Nut, 1/2 Nylon Lock	12
14	30163	Cotter Key, 1/8 x 1	2
15	36070	Pin, Hinge	1
16	36395	Auger Fork	1
17	36370	Retrieval Ring	1
18	36380	Pin, Retrieval, 9"	1
19	36379	Pin, Retrieval Attachment incl. Hairpin, 4 1/4"	1
20	9059-1	Hairpin Cotter	1
21	36385	Adaptor, Heavy Duty, Hydraulic	1
22	3012-3	Washer, Lock, 3/8"	1
23	3012-2P	Socket Head Cap Screw, 3/8 x7/8 with Nylon Locking Plug	1
24	9021	Set Screw, Incl. with Adaptor	1
25	36092	Grease Fitting, Extension	1
26	36091	Elbow, 45 deg. 1/8" NPT	1
27	36095	Clamp Assembly	1
28	3012-2	Bolt, 3/8 x 1	4
29	3012-3	Washer, Lock, 3/8"	2
30	30154	Nut, 3/8 Nylon Lock	2
31	30408	Bolt, 1/2 x 1-1/2	6
32	6532	Bolt, 1/2 x 2	2
33	36382	Pin, Adaptor incl. Hairpin, 3 1/4" OAL	1



VALVES AND MOUNTING

Section

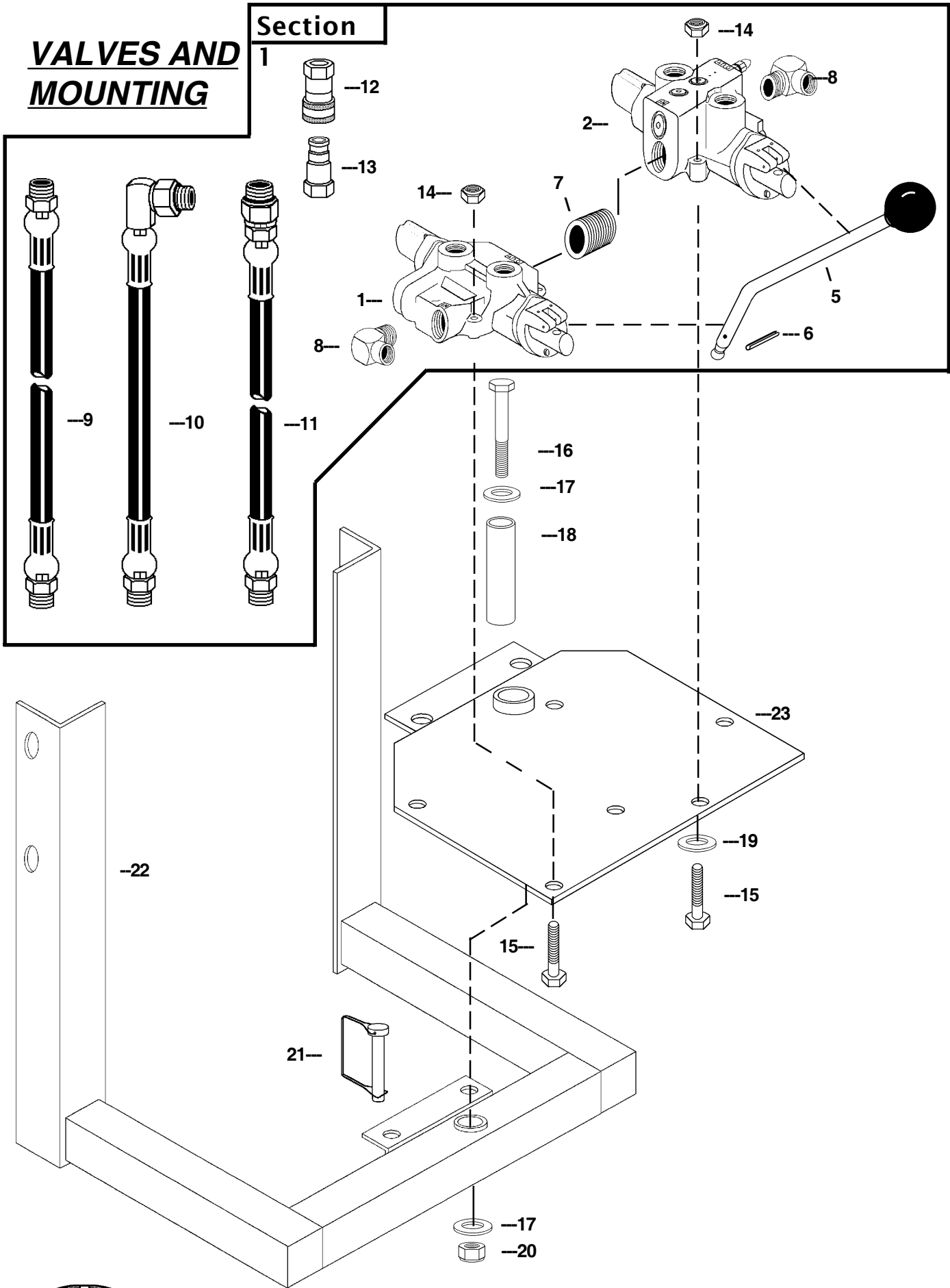

VALVES AND MOUNTING

<u>ITEM #</u>	<u>PART #</u>	<u>DESCRIPTION</u>	<u>QTY</u>
---------------	---------------	--------------------	------------

SECTION 1 - FOR VALVES WITH O-RING PORTS - SER #0286 AND ABOVE

1	36512	Valve, Hyd. 4-Way,, Auger Rotation	1
	36334	Seal Kit, (not pictured) for above Valve	1
2	36511	Valve, Hyd. 4-Way, Auger Lift	1
	36331	Seal Kit, (not pictured) for above Valve	1
5	36338	Handle, Valve	1
6	363432	Roll Pin, 1/8 x 1"	1
7	36514	Nipple, Straight, O-Ring, Close Nipple	1
8	30298	Fitting, Elbow	2
	AND 30282	Fitting, Reducer	2
9	36355	Hose Assy., Hyd. 1/2 x 144	2
10	36515	Hose Assy., Hyd. 1/2 x 22	2
11	36516	Hose Assy., Hyd. 1/2 x 75	2
12	35260	Coupling, Quick Disconnect, Female	1
13	35261	Coupling, Quick Disconnect, Male	1
14	30204	Nut, 1/4" Nylon Lock	6

SECTION 1 - FOR VALVES WITH PIPE THREAD PORTS - SER #0285 AND BELOW

1	36340	Valve, Hyd. 4-Way,, Auger Rotation	1
	36334	Seal Kit, (not pictured) for above Valve	1
2	36335	Valve, Hyd. 4-Way, Auger Lift	1
	36331	Seal Kit, (not pictured) for above Valve	1
5	36338	Handle, Valve	1
6	36343	Roll Pin, 1/8 x 1-3/8	1
7	35290	Nipple, 3/4 NPT Close	1
8	30414	Fitting, Elbow, 90 deg. 3/4 NPT x 1/2 NPT	2
9	36355	Hose Assy., Hyd. 1/2 x 144	2
10	36345	Hose Assy., Hyd. 1/2 x 22	2
11	36350	Hose Assy., Hyd. 1/2 x 75	2
12	35260	Coupling, Quick Disconnect, Female	1
13	35261	Coupling, Quick Disconnect, Male	1
14	30204	Nut, 1/4" Nylon Lock	6

SECTION 2 - FOR EITHER VALVE STYLE

15	5077	Bolt, Hex, 1/4 x 1-3/4	6
16	36408	Bolt, Hex, 1/2 x 3-1/2	1
17	30153	Washer, 1/2 Flat	2
18	36305	Bushing, Pivot	1
19	4204	Washer, 1/4 Flat	6
20	30158	Nut, 1/2 Nylon Lock	1
21	6554	Pin, Snapper, 5/16"	1
22	36290	Bracket, Valve	1
23	36300	Valve Plate, Weldment	1



AUGER LIFT DRIVE

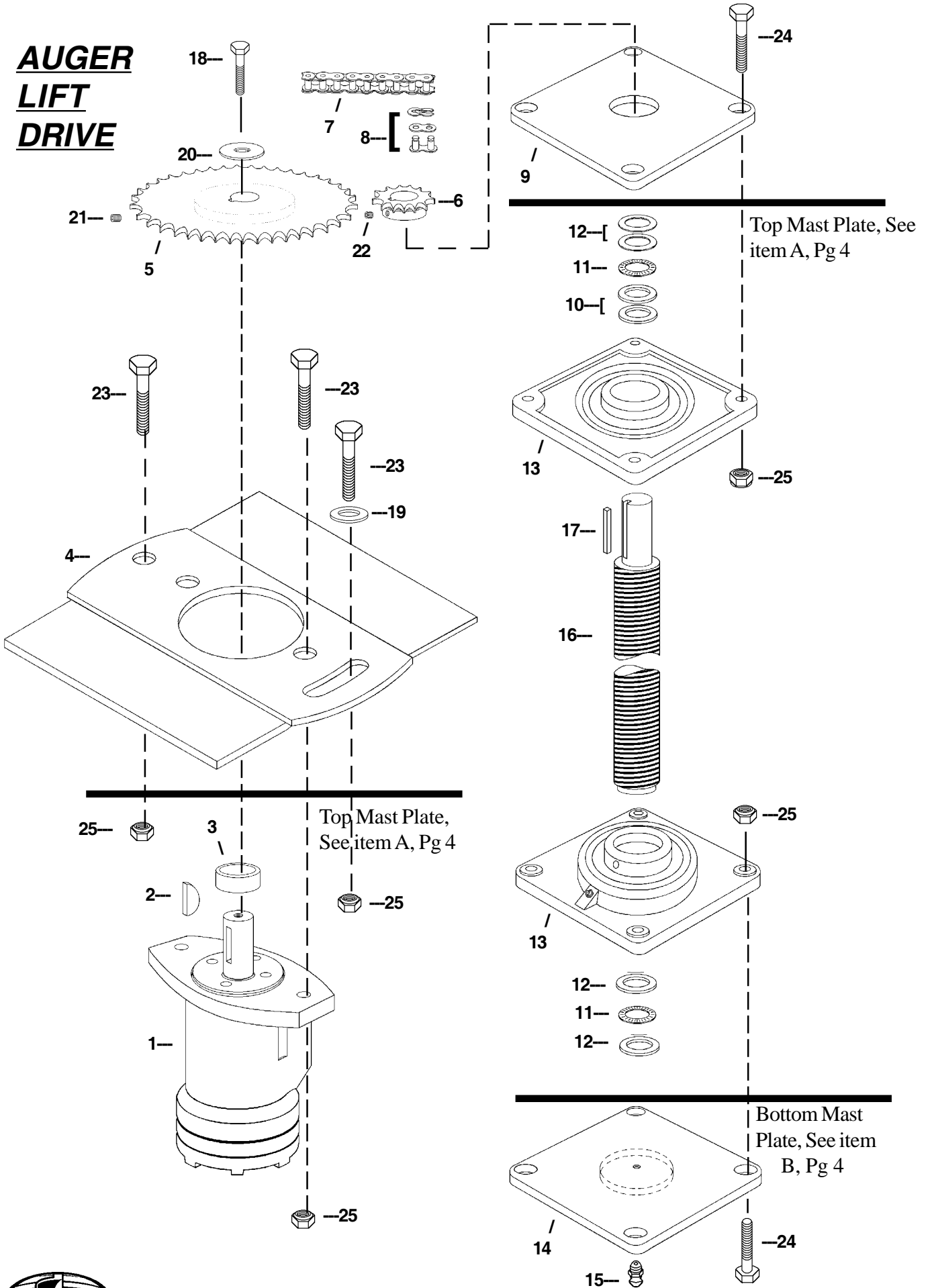

AUGER LIFT DRIVE

ITEM #	PART #	DESCRIPTION	QTY
1	30191-8	Motor, Hyd. Shaft Drive	1
2	30182	Key, Woodruff, 1/4 x 1	1
3	36310	Spacer	1
4	36145	Motor Mounting Plate	1
5	36315	Sprocket, 48 Tooth, 40 RC	1
6	36320	Sprocket, 12 Tooth, 40 RC	1
7	36325	Roller Chain, ANSI No. 40 (65 Links)	1
8	36330	Link, Connecting No. 40 RC	1
9	36155	Plate, Top Bearing	1
10	36221	Washer, Thrust, 1/32"	2 or as needed
11	36220	Bearing, Thrust 1	2
12	36223	Washer, Thrust, 3/32	4
13	36215	Bearing, Flange, 1-1/2	2
14	36140	Plate, Bottom	1
15	9036	Grease Fitting	1
16	36150	Drive Shaft, Threaded	1
	36151	Drive Shaft, Threaded, XL	1
17	4081	Key	1
18	9024-BP	Bolt, 1/4 x 1	1
19	30153	Washer, 1/2 Flat	1
20	5053	Washer, 1/4 Flat 1-1/4 OD	1
21	30171	Set Screw, 5/16-18 x 5/16	1
22	9021	Set Screw, 1/4-20 x 1/4	1
23	30408	Bolt, 1/2 x 1-1/2	4
24	6532	Bolt, 1/2 x 2	8
25	30158	Nut, 1/2 Nylon Lock	12



DRILL FRAME ASSEMBLY

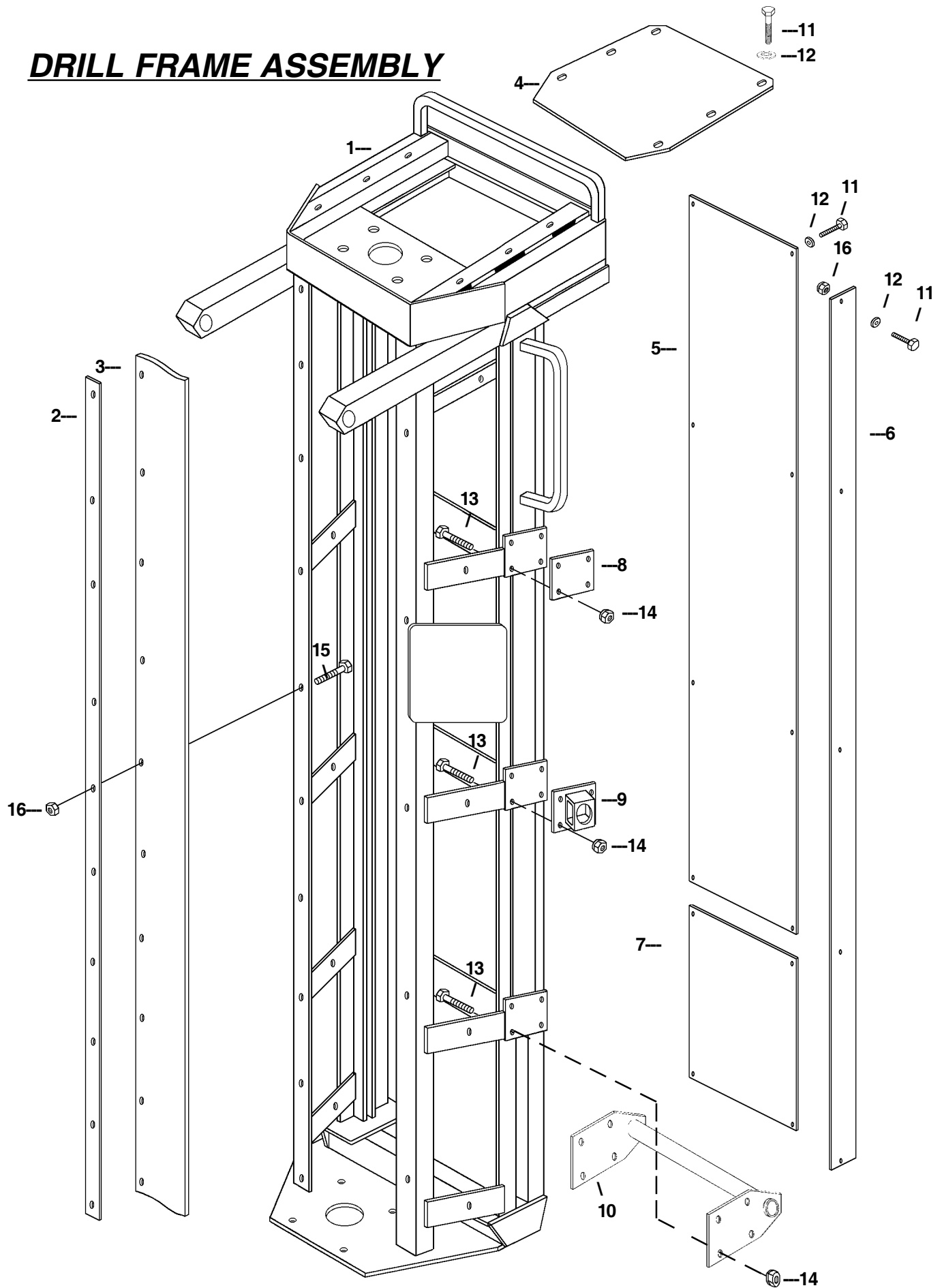

DRILL FRAME ASSEMBLY

ITEM #	PART #	DESCRIPTION	QTY
1	36000	Drill Frame Only	1
	36600	Drill Frame Only, XL	1
2	36190	Bar, Front Guard	2
	36606	Bar, Front Guard, XL	2
3	36210	Guard, Front	2
	36607	Guard, Front, XL	2
4	36225	Plate, Cover	1
5	36195	Cover, Rear	1
	36610	Cover, Rear, XL	1
6	36205	Cover, Side	2
	36608	Cover, Side, RH, XL	1
	36609	Cover, Side, LH, XL	1
7	36200	Cover, Rear Bottom	1
8	36160	Plate, Side	2
9	36110	Bracket, Trunion Mounting	2
10	36105	Bracket, Pivot	1
11	4008-1	Cap Screw, 1/4 x 5/8 Gr 5	18
12	4034-1	Washer, 1/4" SAE Flat	28
13	30408	Cap Screw, 1/2 x 1-1/2 Gr 5	24
14	30158	Nut, 1/2" Fiber-Lock	24
15	9024-BP	Cap Screw, 1/4 x 1 Gr 5	20
16	30204	Nut, 1/4" Fiber-Lock	30
17	9024	Bolt, 1/4 x 7/8	10



MOBILE FRAME **ASSEMBLY**

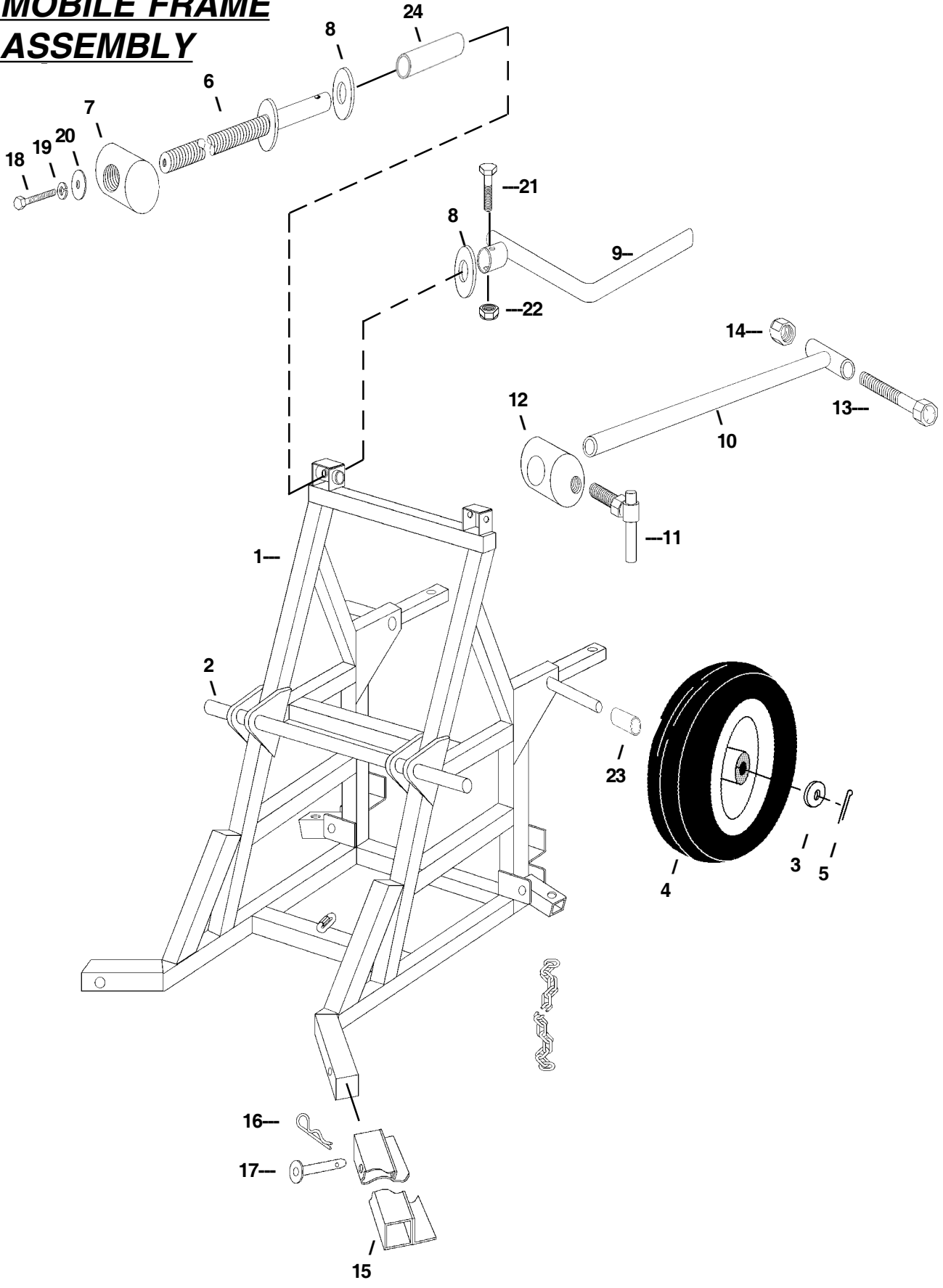

MOBILE FRAME ASSEMBLY

ITEM #	PART #	DESCRIPTION	QTY
1	36245	Frame, Mobile	1
	36615	Frame, Mobile, XL	1
2	36185	Pin, Pivot	1
3	30164	Washer, Flat 3/4	4
4	40631	Wheel, 16" with 3/4" Bore	2
5	36298	Cotter Pin, 1/4 x 1-3/4	4
6	36115	Shaft, Angle Adjustment	1
7	36165	Trunion, Drill Frame	1
8	36117	Washer, 1" Plain	2
9	36120	Handle, Crank	1
10	36125	Brace, Slide Bar	1
11	36130	Handle, Brace	1
12	36135	Trunion, Brace	1
13	36118	Bolt, Hex, 3/4 x 4	1
14	9096	Nut, 3/4 Nylon Lock	1
15	36279	Foot, Left Hand (shown)	1
	36278	Foot, Right Hand (not shown)	1
16	9059-1	Hairpin Cotter	2
17	9059	Pin, Auger incl. Hairpin, 2 3/4" OAL	2
18	9024-BP	Bolt, Hex 1/4 x 1	1
19	9025	Washer, Lock 1/4	1
20	5053	Washer, Flat 1/4 x 1-1/4 OD	1
21	5077	Bolt, Hex 1/4 x 1-3/4	1
22	30204	Nut, 1/4 Nylon Lock	1
23	36280	Bushing	2
24	36175	Bushing, Trunnion	1



TORQUE TUBE AND STAY

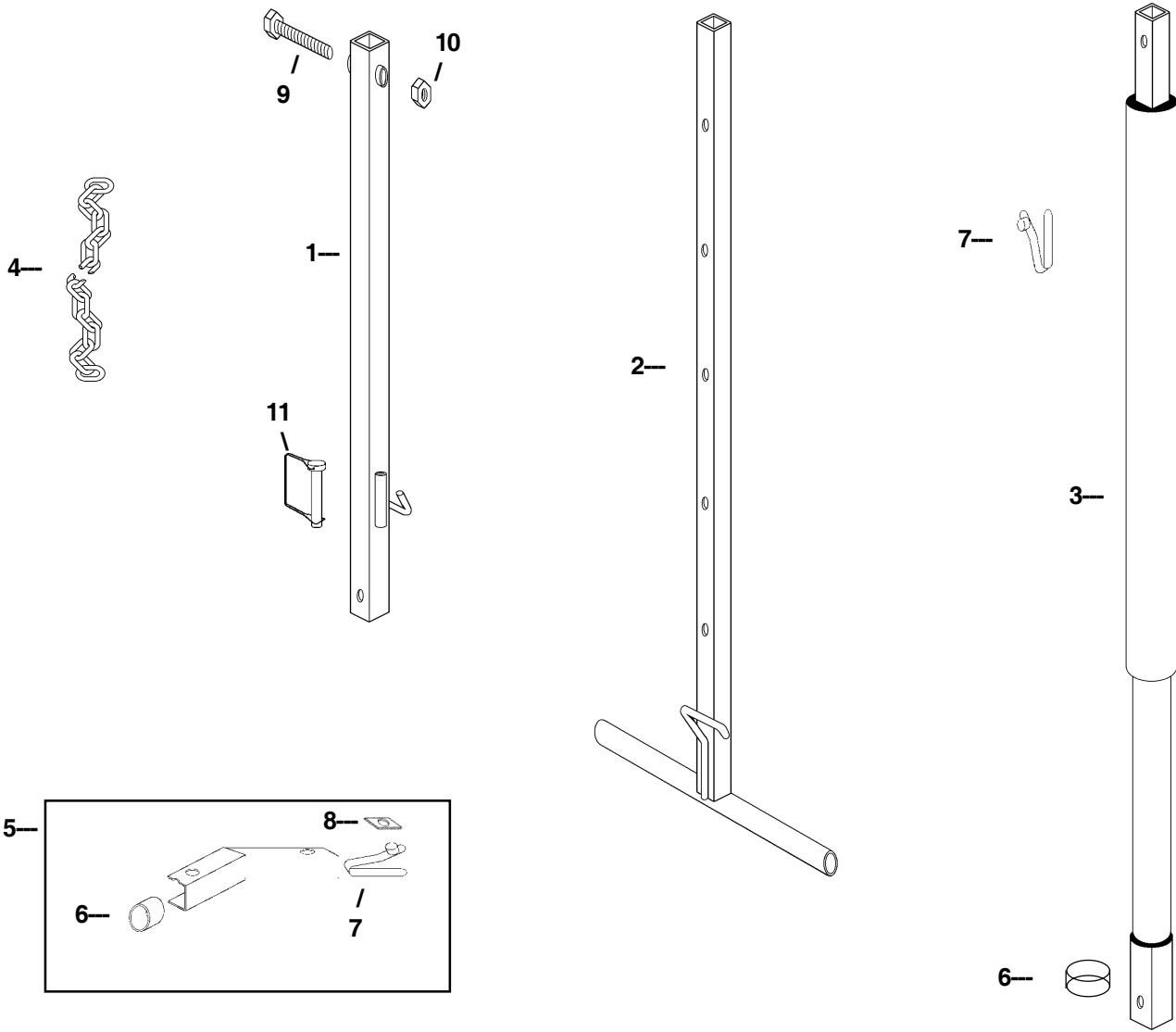

ITEM #	PART #	DESCRIPTION	QTY
1	36235	Back Stay, Pivot	1
2	36240	Back Stay, Foot	1
	36525	Back Stay, Foot, XL	1
3	9092	Torque Tube, No-Pull-Out	1
4	36285	Chain, 6 foot, 3/16" Proof Coil	1
5	36403	Adaptor Assy., 45 deg. Torque Tube	1
6	9058-1	Button Shield	2
7	9058	Spring & Button	2
8	9084-1	Pad, Button	1
9	36408	Bolt, Hex N/C 1/2 x 3-1/2	1
10	30158	Nut, 1/2" Fiber-Lock	1
11	6511	Pin, Snapper, 3/8"	1



BIG BEAVER SAFETY SIGN AND DECALS

⚠ DANGER

NEVER DRILL HOLES WHERE THERE IS A POSSIBILITY OF UNDERGROUND POWER CABLES OR OTHER HAZARDS

DRILL HEAD CONTROLS

Ⓜ

↑

↓

Ⓣ

RAISE

↑

↓

LOWER

 **LITTLE BEAVER, INC.**, P.O. BOX 840, LIVINGSTON, TX 77351 409/327-3121

⚠ WARNING

FAILURE TO OBSERVE SAFETY INSTRUCTIONS AND PRACTICES CAN CAUSE PROPERTY DAMAGE, SERIOUS BODILY INJURY AND/OR DEATH.

⚠ CAUTION

1. **READ AND UNDERSTAND THE OPERATOR'S MANUAL BEFORE OPERATING.** IF OPERATOR'S MANUAL IS NOT AVAILABLE, CALL OR WRITE FOR FREE REPLACEMENT.
2. KEEP ALL SAFETY SHIELDS AND DEVICES IN PLACE.
3. MAKE CERTAIN EVERYONE IS CLEAR BEFORE OPERATING
4. KEEP HANDS, FEET AND CLOTHING AWAY FROM MOVING PARTS.
5. SHUT OFF POWER TO ADJUST, SERVICE OR CLEAN.
6. RELIEVE HYDRAULIC PRESSURE BEFORE DISCONNECTING LINES.
7. NEVER OPERATE DRILL WITHOUT CORRECTLY INSTALLING TORQUE TUBE.
8. LOWER DRILL HEAD BEFORE MOVING THE MACHINE.

1 /

2-

⚠ DANGER



To prevent serious injury or death from pinching and rotating auger:





★ Keep all persons and objects clear while any part of this machine is in motion.

ITEM #	PART #	DESCRIPTION	QTY
1	36232	Safety Sign, Big Beaver	1
2	36233	Decal, Danger, Prevent Injury	2

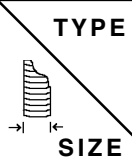

NOTES:

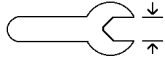
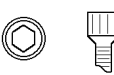
IMPORTANT: All nuts, fasteners, and fittings must be kept tightened. Refer to torque chart for proper assembly torque.

HEX HEAD					
 TYPE SIZE	 GRADE 5	 GRADE 8	 WRENCH SIZE		 WRENCH SIZE
				inch	
No. 4	8 in lb	12 in lb	1/4"	12 in lb	3/32"
No. 6	16 in lb	23 in lb	5/16"	21 in lb	7/64"
No. 8	30 in lb	41 in lb	11/32"	42 in lb	9/64"
No.10	43 in lb	60 in lb	3/8"	60 in lb	5/32"
1/4"	8 ft lb	12 ft lb	7/16"	12 ft lb	3/16"
5/16"	17 ft lb	25 ft lb	1/2"	24 ft lb	1/4"
3/8"	30 ft lb	45 ft lb	9/16"	43 ft lb	5/16"
7/16"	50 ft lb	70 ft lb	5/8"	69 ft lb	3/8"
1/2"	75 ft lb	110 ft lb	3/4"	105 ft lb	3/8"
9/16"	110 ft lb	150 ft lb	13/16"	158 ft lb	-----
5/8"	150 ft lb	220 ft lb	15/16"	195 ft lb	1/2"
3/4"	260 ft lb	380 ft lb	1-1/8"	353 ft lb	5/8"

HYDRAULIC FITTINGS

<u>SIZE</u>	<u>TORQUE</u>	<u>SIZE</u>	<u>TORQUE</u>
1/4 NPT	25 ft.lb.	7/16-20 SAE O-Ring	12 ft.lb.
3/8 NPT	50 ft.lb.	9/16-18 SAE O-Ring	20 ft.lb.
1/2 NPT	75 ft.lb.	3/4-16 SAE O-Ring	35 ft.lb.
3/4 NPT	110 ft.lb.	7/8-14 SAE O-Ring	50 ft.lb.
		1-1/16-12 SAE O-Ring	70 ft.lb.



**THINK
SAFETY
FIRST!**

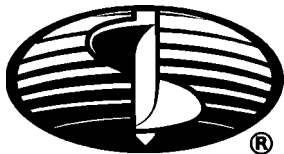

LITTLE BEAVER, INC.

P.O. BOX 840 • LIVINGSTON, TEXAS 77351

® PHONE 936/327-3121 • FAX 936/327-4025

Web: www.littlebeaver.com • E-Mail: sales@littlebeaver.com